

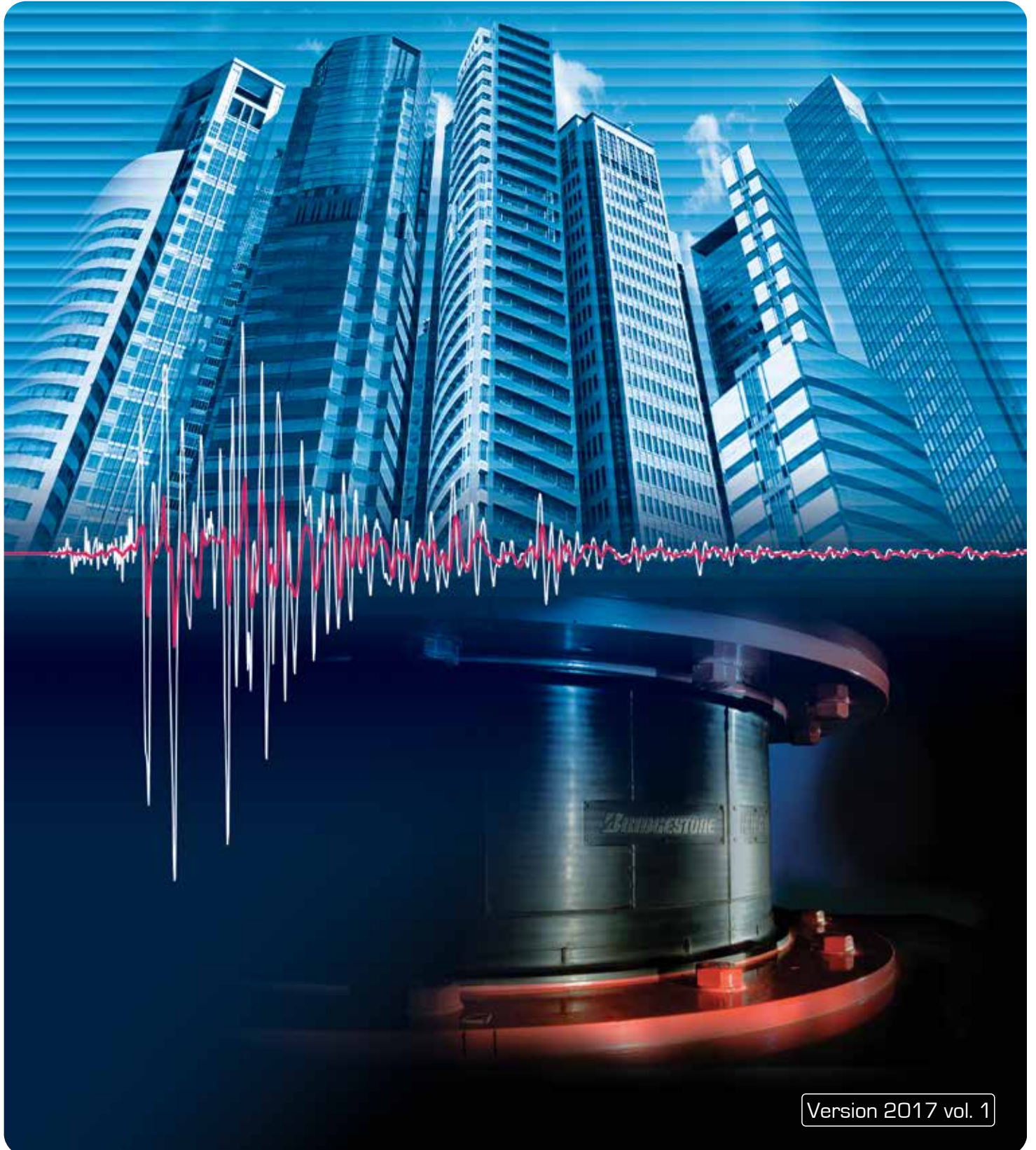

Seismic Isolation Product Line-up

High Damping Rubber Bearing Lead Rubber Bearing

Natural Rubber Bearing Elastic Sliding Bearing



Bridgestone Seismic Isolation Product Line-up

We will meet the customer needs with our new product line-up

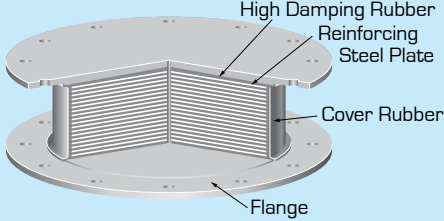
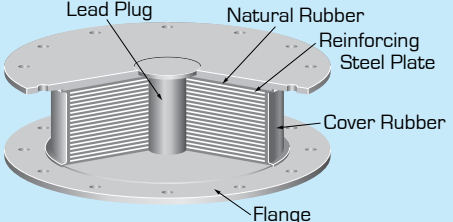
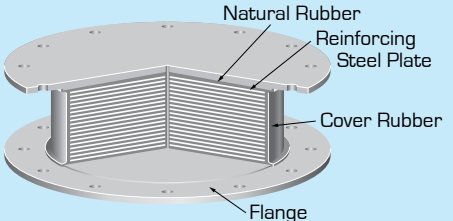
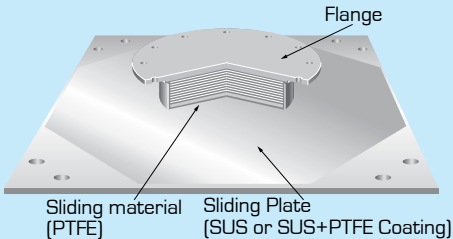
	Features	Sectional View
<h2>HDR</h2> <p>High Damping Rubber Bearing</p>	<p>High damping rubber includes both spring and damping characteristics. Generally, a separate damper is not required, making it an excellent choice for areas with space constraints. Since its hysteresis curves are relatively smooth, seismic isolation can also be extended to the equipment inside the building. There are 3 different elastic moduli available (X0.3R, X0.4S, X0.6R). From light column loads until high rise building can be accommodated.</p>	
<h2>LRB</h2> <p>Lead Rubber Bearing</p>	<p>This bearing includes a lead plug embedded at the centre of a laminated natural rubber structure, where the rubber incorporates the spring capability and the lead plug provides the damping capability. Generally, a separate damper is not required making it a good choice for areas with space constraints. Its hysteresis resembles elastoplastic materials. The attenuation can be tuned by varying the lead plug diameter. One type of rubber material is available (G0.40).</p>	
<h2>NRB</h2> <p>Natural Rubber Bearing</p>	<p>This bearing uses natural rubber, which inherently has a low damping ratio (about 2~3% equivalent damping ratio), excellent linearity, and a stable restoring force. A separate damper is required, but the overall isolation design has much greater flexibility. Four different kinds of elastic moduli are available (G0.30 , G0.35 , G0.40 , G0.45) to support a wide range of column loads.</p>	
<h2>Elastic Sliding Bearing</h2>	<p>This bearing consists of 2 pieces: 1) a natural rubber bearing bonded with PTFE (Teflon) material and; 2) a stainless steel slide plate. Small displacements are absorbed by the rubber itself, while large displacements cause the rubber bearing to slide on the plate. Since there is no restoring force, the slide bearing is normally used in combination with NRB, LRB or HDR. Two different coefficients of friction are available to suit the damping requirements.</p>	

Note: The above diagram and hysteretic loop are for illustrative purpose only.

Hysteretic Loop

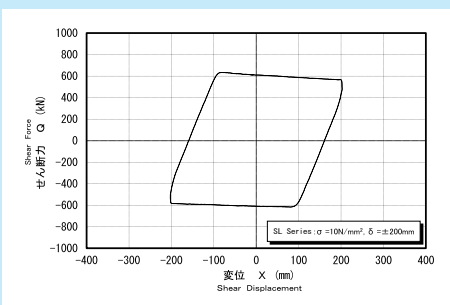
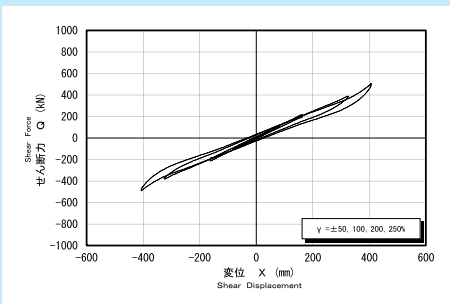
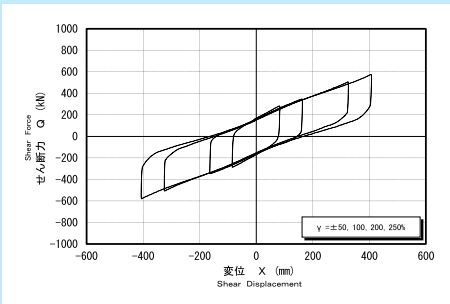
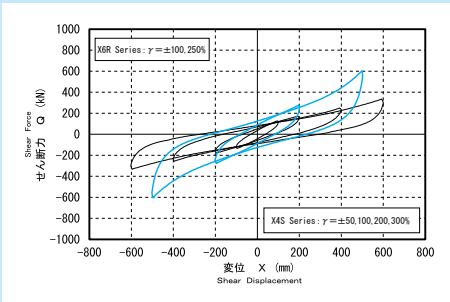

Content

Bridgestone Seismic Isolation product line up	1
HDR LRB NRB Elastic Sliding Bearing	
Introduction of Product & System.....	3
High Damping Rubber Bearing X Series	3
Layout Planning Assistance Program	5
Product Specification & Performance Characteristic	6
High Damping Rubber Bearing (HDR)	6
Lead Rubber Bearing (LRB)	9
Natural Rubber Bearing (NRB).....	11
Elastic Sliding Bearing.....	13
Product Specification	15
High Damping Rubber Bearing (HDR).....	15
Certification Number MVBR-0516 (X0.3R)	
Certification Number MVBR-0510/MVBR-0519 (X0.4S)	
Certification Number MVBR-0514/MVBR-0520 (X0.6R)	
HM Series (Total Rubber Thickness 16cm).....	15
HN Series (Total Rubber Thickness 20cm).....	16
HH Series (Total Rubber Thickness 20cm).....	17
HL Series (Total Rubber Thickness 16cm).....	19
HT Series (Total Rubber Thickness 25cm).....	21
HS Series ($S_2 = 5$).....	23
HD Series (Total Rubber Thickness 32cm).....	24
Lead Rubber Bearing (LRB)	25
Certification Number MVBR-0517	
Lead Plug Diameter List	25
LH Series (Total Rubber Thickness 20cm).....	27
LL Series (Total Rubber Thickness 16cm)	36
LT Series (Total Rubber Thickness 25cm).....	43
LD Series (Total Rubber Thickness 32cm).....	50
LS Series ($S_2 = 5$).....	53
Natural Rubber Bearing (NRB).....	62
Certification Number MVBR-0295 (N3,G3,G5)	
Certification Number MVBR-0509/MVBR-0518 (G4)	
NS Series ($S_2 = 5$).....	62
NH Series (Total Rubber Thickness 20cm).....	66
NL Series (Total Rubber Thickness 16cm)	67
NT Series (Total Rubber Thickness 25cm).....	68
ND Series (Total Rubber Thickness 32cm).....	69
Elastic Sliding Bearing.....	70
Certification Number MVBR-0349	
SL Series ($\mu = 0.13$ & G1.2).....	70
Others	71
Compact Flange.....	71
Dustproof Cover	72
Precautions for Safe Use of Seismically Isolated Bearing.....	73

Product & System Introduction

High Damping Rubber Bearing X Series

Features of High Damping Rubber Bearing X Series

High damping rubber bearing is a laminated rubber structure that includes a special filler compound in the rubber itself to provide energy absorption performance. It combines damping and spring characteristics and is widely adopted as a seismic isolator.

However, the conventional high damping rubber shows loading hysteresis dependency, where its rate of change of stiffness has become reduced and restoration becomes progressively worse after repeated loading under increasing deformation. With Bridgestone's next-generation of high damping rubber X series, the effect of loading hysteresis dependency is greatly reduced and the properties become much simpler to manage. Furthermore, it is also more accommodating to the reduction in ultimate properties caused by bi-directional loading.

● Reduction in Loading Hysteresis Dependency

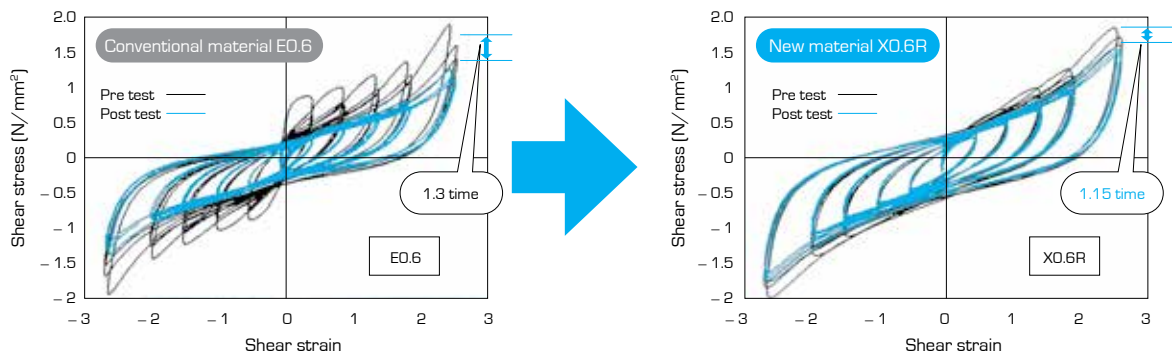

Compared to conventional high damping rubber, the change of equivalent shear stiffness (1 cycle/3cycle) in repeated loading is greatly reduced. The properties of seismic isolation bearings are defined by the 3rd cycle and it is able to reduce the load variation during initial deformation.

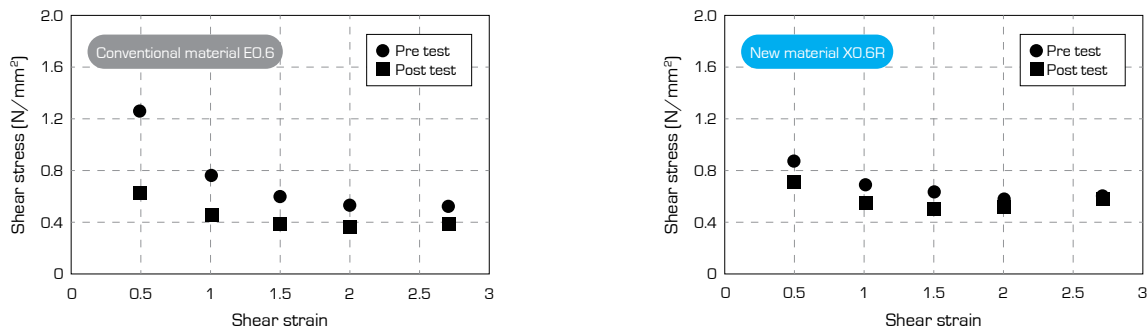

Conventional high damping rubber shows shear stress reduction after large deformation due to the effect of loading hysteresis dependency, but the next-generation high damping rubber is able to minimize the change in properties before and after large deformation. By reducing the effect of loading hysteresis dependency, the accuracy of the overall seismic isolation design can be improved.

● Increasing of Equivalent Damping Ratio

Compared to conventional high damping rubber, the equivalent damping ratio (at shear strain $\gamma = \pm 100\%$) of high damping rubber X0.4S, X0.6R are increased (X0.4S:0.220 \rightarrow 0.240, X0.6R:0.225 \rightarrow 0.240). Furthermore, compared to the same diameter of lead rubber bearing (lead diameter/outer diameter = 0.2), a higher damping ratio can be obtained in the range of $\gamma \geq 130\%$.

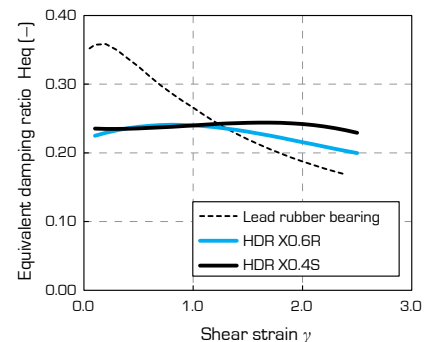

Ultimate Properties of High Damping Rubber Bearings by Horizontal Bi-directional Loading

● Outline

The ultimate deformation of high-damping rubber is degraded by applying bi-directional loading compared to unidirectional loading. Through a horizontal bi-directional loading test with a full scale model high-damping rubber bearing, torsional deformation can be seen in the side view of the rubber. Compared with unidirectional loading, the phenomenon of breaking at early stage by bi-directional loading has been identified. The standard value of the ultimate properties, influenced by bi-directional loading is shown below and the ultimate compressive stress is confirmed.

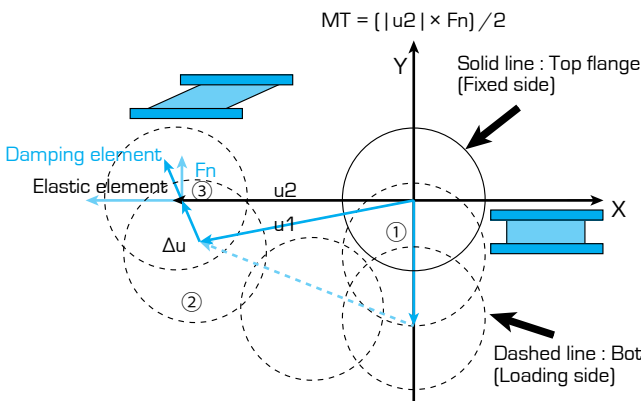

Figure 1: The mechanism of torsional deformation

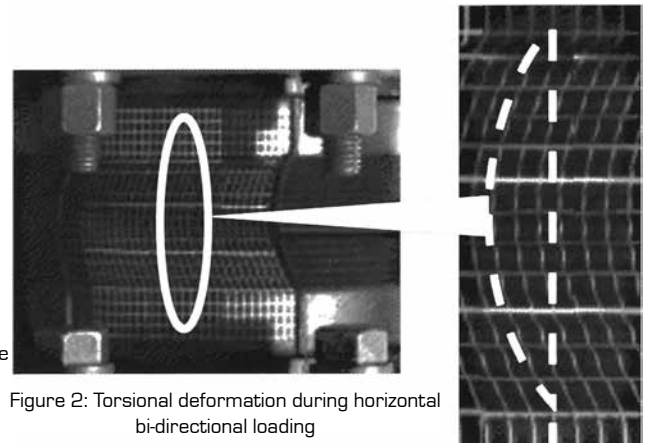

Figure 2: Torsional deformation during horizontal bi-directional loading

As shown in Figure 1, when the bi-directional loading is applied on a high damping rubber bearing, the elastic force occurs in the shear deformation direction, while the damping force occurs in the tangential direction of the deformation trajectory. The torsional moment created by the damping elements and the shear deformation is present at each rubber layer of the laminated structure. The additional shear strain γ_{\varnothing} caused by torsional deformation is added to the shear strain caused by the rubber shear deformation itself. Thus, it will rupture relatively early compared to the unidirectional loading test. However, the torsional deformation caused by bi-directional loading does not affect the buckling ultimate strain, as verified experimentally.

● Ultimate Property of Horizontal Bi-directional Loading

According to the Japan Society of Seismic Isolation (JSSI) guidelines, the final ultimate strain is determined by the minimum of the ultimate strain γ_L by unidirectional loading and the ultimate strain γ_{Bo} by bi-directional loading.

● Ultimate strain by unidirectional loading

Ultimate strain by unidirectional loading is defined as shown in Table 1.

Table 1: Standard value of ultimate strain by unidirectional loading

Compound	Ultimate strain by unidirectional loading γ_L
XO.4S	$S_2 \times 0.9 \times 100\%$ ($0.9 \times S_2 < 4$) 400% ($0.9 \times S_2 \geq 4$)
XO.6R	$S_2 \times 0.9 \times 100\%$ ($S_2 < 4.5$) 400% ($S_2 \geq 4.5$)

S_2 : Second shape factor

● Ultimate strain by bi-directional loading

Ultimate strain by bi-directional loading is defined as shown in Table 2.

Table 2: Standard value of ultimate strain by bi-directional loading

Compound	Formula of ultimate strain by bi-directional loading γ_{Bo}
XO.4S	$\gamma_{Bo} = (5.80 \times S_2 + 9.05) / (S_2 + 4.49)$
XO.6R	$\gamma_{Bo} = (5.00 \times S_2 + 9.05) / (S_2 + 4.49)$

S_2 : Second shape factor

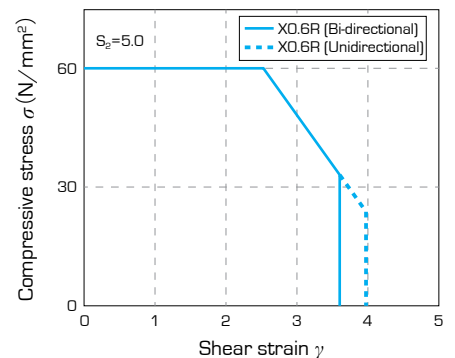
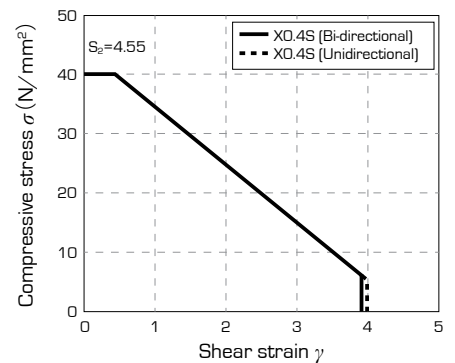

Figure 3: Comparison example of ultimate property diagram

LAP² + t.Ver2 (Layout Planning Assistance Program for Seismic Isolation Device)

LAP² + t.Ver2 is a program that supports layout planning of Bridgestone seismic isolation bearing for seismically isolated building. The ideal seismic isolation bearing (in terms of size) can be determined from the column axial force (nominal long term column load) and the selections of seismic isolation bearing's series based on the layout of the seismic isolation interface. In addition to Bridgestone made seismic isolation bearings, hysteresis type dampers or oil dampers which are typically used in Japan can be specified in the program. The selections can be changed (or specified) interactively on the GUI (Graphic User Interface) screen by the click of a mouse and the notification calculation for that bearing arrangement can be carried out as well. Besides, regarding to the bearing layout planning, the mathematical process which is using genetic algorithm could produce an optimization function whereby by satisfying the notification calculation and at the same time reduce as much as possible the shear force for the layout plan, or by satisfying the notification calculation and at the same time reduce as much as possible the response displacement for the layout plan that could meet the criterias. In addition to being able to verify by the notification calculation, the Lap² + t.Ver2 software allows response calculation for seismic response analysis.

● Simple Input

From the data-input and modification of the seismic isolation interface, seismic response analysis can be conducted easily. Also, Lap² + t.Ver2 is compatible software that can capture or transfer structural calculation data from the "Super Build / SS3" software which is developed by Union System.

● "Super Build / SS3" is a registered trademark of Union System Inc.

● 2 Calculation Functions of Seismically Isolated Structure

● "Seismic Response calculation by seismic isolation notification*1"the results of the calculation can be printed in a reporting style.

● "Seismic response calculation by time history analysis".....the calculation can be conducted for various earthquake waves. Also, Lap² + t.Ver2 can work together with the structural calculation software "Super Dynamic Pro" from Union System.

※ 1 The structural calculation method is based on the "Technical standards required for safety which relates to the structural method for seismically-isolated buildings" as stated in the notification No.2009 of the Ministry of Construction, in the year 2000.

● Seismic Isolation Devices

Bridgestone natural rubber bearing, lead rubber bearing, high damping rubber bearing, elastic sliding bearing, other standard hysteretic dampers and oil dampers can be adopted.

● Layout Planning of Seismic Isolation Devices

The software helps you to choose the appropriate seismic isolation devices and its placement in the building to satisfy the target performance.

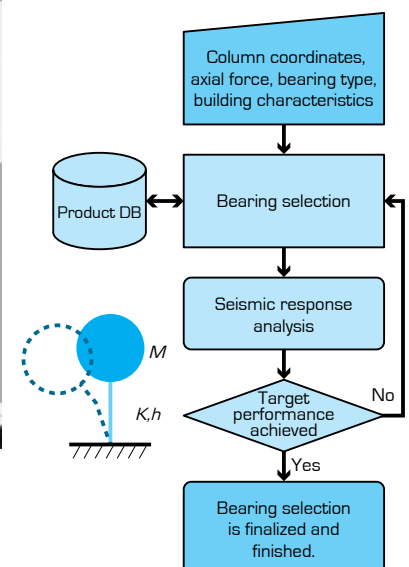
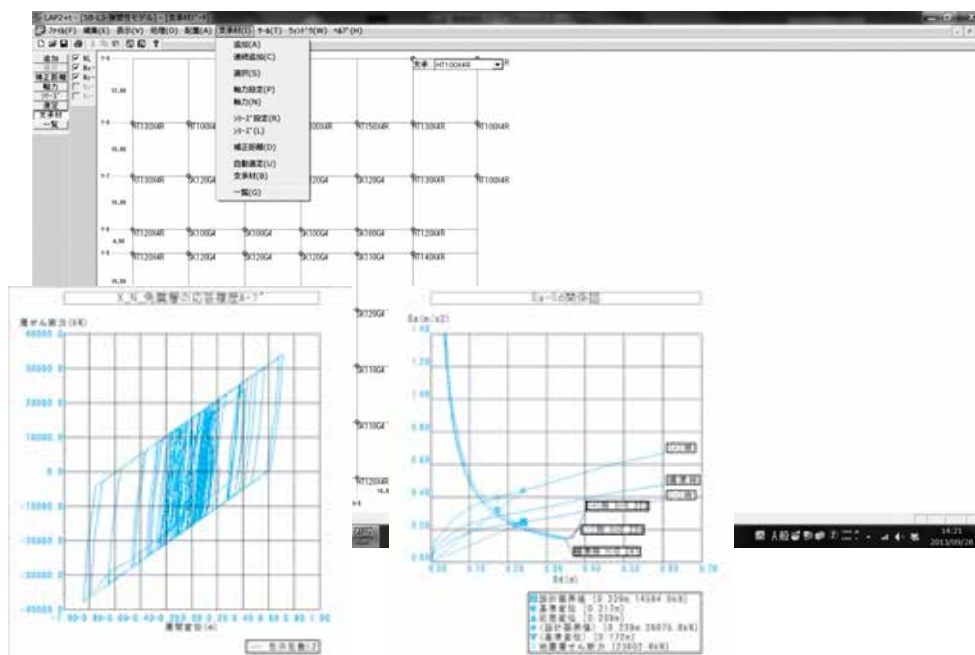

Product Specification & Description of Performance Characteristics

High Damping Rubber Bearing (HDR)

Seismic isolation material certification number by Ministry of Land, Infrastructure and Transport, Japan
MVBR-0516 (XO.3R Series) Acquired in December 2014
MVBR-0510/MVBR-0519 (XO.4S Series) Acquired in December 2014
MVBR-0514/MVBR-0520 (XO.6R Series) Acquired in December 2014

Product Dimension

Characteristics			Sectional View	
Physical Dimensions	Outer diameter	: D_o (mm)		
	Inner diameter	: D_i (mm)		
	Number of inner diameter	: n_i		
	Effective plane area	: A ($\times 10^2$ mm ²)		
	Thickness of one rubber layer	: t_r (mm)		
	Number of rubber layers	: n		
	Total rubber thickness	: $H = n \cdot t_r$ (mm)		
	First shape factor $S_1 = (D_o^2 \cdot n_i \cdot D_i^2) / \{4 \cdot t_r \cdot (D_o + n_i \cdot D_i)\}$			
	Second shape factor $S_2 = D_o / (n \cdot t_r)$			
	Diameter of flange	: D_r (mm)		
	Thickness of flange: edge/center	: t_e / t_c (mm)		
	Connecting bolt PCD	: PCD (mm)		
	Diameter of connecting bolt hole \times qty	: d_b (mm) \times qty		
	Bolt size (assumption)	: M ($d_b - 3$)		
	Thickness of each reinforced steel plate	: t_s (mm)		
Total height	: H_t (mm)			
Total weight 1 [kN] = 1 / 9.80665 [tonf]				

Rubber Material

Notation of rubber kind (standard temperature 20°C standard strain $\gamma = 100\%$)

Compound name	Rubber code	Shear modulus G_{eq} (N/mm ²)	Equivalent damping ratio H_{eq}
X3R	XO.3R	0.300	0.17
X4S	XO.4S	0.392	0.24
X6R	XO.6R	0.620	0.24

Composition of rubber materials (weight ratio %)

Rubber code	Natural rubber	Synthetic rubber	Filler, Reinforcement agent	Vulcanization agent and others
Inner Rubber	XO.3R	35 and above	15 and above	50 and below
	XO.4S	35 and above	20 and above	45 and below
	XO.6R	35 and above	25 and above	40 and below
Cover rubber	40 and above	15 and above	40 and below	

Properties of rubber materials

Item	Tensile strength (N/mm ²)	Elongation at Break (%)	Hardness (JIS A)	100% modulus (N/mm ²)	Young's modulus E (N/mm ²)	Bulk modulus E_v (N/mm ²)	Correction factor for apparent Young's modulus according to hardness, k
Test Standard	JIS K6251	JIS K6251	JIS K6253	JIS K6251	-	-	-
Inner Rubber	XO.3R	7 and above	700 and above	34 \pm 8	0.53 \pm 0.2	4.0	1150
	XO.4S	7 and above	840 and above	37 \pm 8	0.43 \pm 0.2	6.2	1300
	XO.6R	8.5 and above	780 and above	53 \pm 5	0.73 \pm 0.2	7.6	1500
Cover rubber	12 and above	600 and above	-	-	-	-	-

Steel Material

Steel material for each part

Part	Material
Reinforced steel plate	SS400 (JIS G 3101)
Flange ^{*1*}	SS400 (JIS G 3101)
Connecting plate ^{*1}	SS400 (JIS G 3101)

*1: Optionally SM490A (JIS G 3106).

*2: Optionally special thickness other than standard thickness.

Anti-rust treatment of flange

Preparation	Remove rust up to blasting quality of SSPC-SP-10 (SIS Sa 2 1/2)
Primer	Zinc-rich paint 75 μ m \times 1 coat
Middle coat	Epoxy resin paint 60 μ m \times 1 coat
Finishing	Epoxy resin paint 35 μ m \times 1 coat
Total film thickness	170 μ m and above

*1: Standard color is gray.

*2: Other kinds of anti-rust treatment are also available. Please contact us for more details.

Precautions

- For mid-storey isolation, fire resistant cover is necessary (according to JSSI provision, HS110X4S cannot apply any fire resistant cover). Please contact fire resistant cover manufacturer who are listed in the JSSI manufacturer list for more details. (http://www.jssi.or.jp/bussiness/kigyou_detail/to-si-base.htm)
- There are two certification numbers for XO.4S, XO.6R due to difference of some manufacturing process. Although their properties values are the same, please fill the certification number as shown in the table on the right in the design documents.

	Rubber size \varnothing 1000 and below	Rubber size \varnothing 1100 and above
XO.4S	Both MVBR-0510/MVBR-0519	MVBR-0510 only
XO.6R	Both MVBR-0514/MVBR-0520	MVBR-0514 only

Shear Properties

Equivalent shear stiffness K_{eq} , equivalent damping ratio H_{eq} , initial stiffness K_1 , post-yield stiffness K_2 , characteristic strength Q_d , Function giving ratio of characteristic strength to maximum shear force of a loop u

Shear properties of HDR is dependent on shear strain amplitude. The shear strain dependency of each property is expressed by the following equations.

<ul style="list-style-type: none"> Rubber material X0.3R ($0.1 \leq \gamma \leq 3.0$) 	$G_{eq}(\gamma) = 0.0255 \gamma^4 - 0.2213 \gamma^3 + 0.7283 \gamma^2 - 1.1028 \gamma + 0.8703$ $H_{eq}(\gamma) = -0.005 \gamma^3 + 0.015 \gamma^2 - 0.006 \gamma + 0.166$ $u(\gamma) = -0.0087 \gamma^3 + 0.0262 \gamma^2 - 0.0105 \gamma + 0.2720$
<ul style="list-style-type: none"> Rubber material X0.4S ($0.1 \leq \gamma \leq 2.7$) 	$G_{eq}(\gamma) = 0.054 \gamma^4 - 0.416 \gamma^3 + 1.192 \gamma^2 - 1.583 \gamma + 1.145$ $H_{eq}(\gamma) = -0.007 \gamma^3 + 0.020 \gamma^2 - 0.009 \gamma + 0.236$ $u(\gamma) = -0.0132 \gamma^3 + 0.0401 \gamma^2 - 0.0190 \gamma + 0.4001$
<ul style="list-style-type: none"> Rubber material X0.6R ($0.1 \leq \gamma \leq 2.7$) 	$G_{eq}(\gamma) = 0.620 \times [0.1364 \gamma^4 - 1.016 \gamma^3 + 2.903 \gamma^2 - 3.878 \gamma + 2.855]$ $H_{eq}(\gamma) = 0.240 \times [0.02902 \gamma^3 - 0.1804 \gamma^2 + 0.2364 \gamma + 0.9150]$ $u(\gamma) = 0.408 \times [0.03421 \gamma^3 - 0.2083 \gamma^2 + 0.2711 \gamma + 0.9028]$

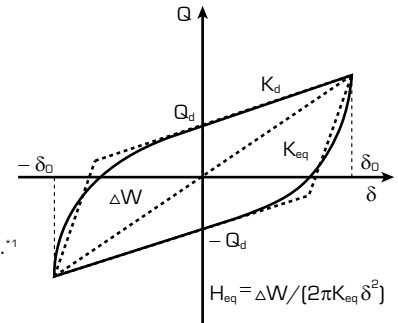

Based on above equations, each shear properties shall be determined by the following equations.¹

Equivalent shear stiffness	: $K_{eq} = G_{eq} \cdot A / H$	Equivalent damping ratio	: $H_{eq} = \Delta W / (2 \pi \cdot K_{eq} \delta^2)$
Initial stiffness	: $K_1 = 10 \times K_2$		
Post-yield stiffness	: $K_2 = K_{eq} (1 - u)$		
Characteristic strength	: $Q_d = u \cdot K_{eq} \cdot H \cdot \gamma$		

* 1: At standard condition only and shall be excluded when considering the properties variation.

Temperature dependency

Each shear properties shall be corrected to the value at standard temperature of 20°C by the following equations. (Applicable range: $-10 \leq T \leq 40^\circ\text{C}$) [T : Temperature during inspection]

<ul style="list-style-type: none"> Rubber material X0.3R 	$K_{eq}(T^\circ\text{C}) = K_{eq}(\text{standard value at } 20^\circ\text{C}) \times [1.139 - 9.653 \times 10^{-3} \cdot T + 1.721 \times 10^{-4} \cdot T^2 - 1.847 \times 10^{-6} \cdot T^3]$ $H_{eq}(T^\circ\text{C}) = H_{eq}(\text{standard value at } 20^\circ\text{C}) \times [1.050 - 2.790 \times 10^{-3} \cdot T + 4.678 \times 10^{-5} \cdot T^2 - 1.613 \times 10^{-6} \cdot T^3]$
<ul style="list-style-type: none"> Rubber material X0.4S/X0.6R 	$K_{eq}(T^\circ\text{C}) = K_{eq}(\text{standard value at } 20^\circ\text{C}) \times [1.205 - 1.862 \times 10^{-2} \cdot T + 5.991 \times 10^{-4} \cdot T^2 - 8.991 \times 10^{-6} \cdot T^3]$ $H_{eq}(T^\circ\text{C}) = H_{eq}(\text{standard value at } 20^\circ\text{C}) \times [1.065 - 4.134 \times 10^{-3} \cdot T + 1.096 \times 10^{-4} \cdot T^2 - 3.102 \times 10^{-6} \cdot T^3]$

Standard value of temperature dependency (Standard temperature [20°C])

Properties values	Equivalent shear stiffness K_{eq}				Equivalent damping ratio H_{eq}			
	-10°C	0°C	30°C	40°C	-10°C	0°C	30°C	40°C
X0.3R	within +25%	within +14%	within -5%	within -9%	within +8%	within +5%	within -4%	within -9%
X0.4S	within +46%	within +21%	within -6%	within -16%	within +12%	within +7%	within -4%	within -12%
X0.6R	within +46%	within +21%	within -6%	within -16%	within +12%	within +7%	within -5%	within -13%

Performance variation

The rate of change of main causes (manufacturing variation, aging, temperature change) which affect shear properties as shown below.

Rubber materials	X0.3R		X0.4S		X0.6R	
	Equivalent shear stiffness, K_{eq}	Equivalent damping ratio, H_{eq} Function giving ratio of characteristic strength to maximum shear force, u	Equivalent shear stiffness, K_{eq}	Equivalent damping ratio, H_{eq} Function giving ratio of characteristic strength to maximum shear force, u	Equivalent shear stiffness, K_{eq}	Equivalent damping ratio, H_{eq} Function giving ratio of characteristic strength to maximum shear force, u
Manufacturing variation ^{*1}	±10%	∓10%	±10%	∓10%	±10%	∓10%
Aging ^{*2}	+10%	-10%	+10%	-10%	+10%	-10%
Ambient temperature variation 20°C ± 20°C	(+) side	+14%	+5%	+21%	+7%	+21%
	(-) side	-9%	-9%	-16%	-12%	-16%
Total	(+) side ^{*3}	+34%	-15%	+41%	-13%	+41%
	(-) side ^{*3}	-19%	+1%	-26%	-2%	-26%

* 1: The variation of each product (standard value) shall be within ±20% and variation of total units of products per project (total of standard values) shall be within ±10%. However, if the total units of products is less than 8 units per project, the variation (total of standard values) shall be within ±15%.

(For H_{eq} , $\Sigma (H_{eq} \times K_{eq}) / \Sigma K_{eq}$ shall be within ±15% from the standard value)

Note: For compressive stiffness K_v , variation of each product (standard value) shall be within ±30%.

* 2: Predicted rate of change after 60 years at 20°C standard temperature.

* 3: The equivalent shear stiffness K_{eq} and equivalent damping ratio H_{eq} is dependent to each other. The indicated rate of change of H_{eq} are corresponding to both maximum and minimum rate of change of K_{eq} respectively.

* 4: Above list shows the combination example.

Compressive Properties

Compressive stiffness K_V

Compressive stiffness K_V is determined by the following equation.

$$K_V = E_C \cdot \frac{A}{H} \quad E_C = \frac{E(1+2\kappa S_1^2)}{1+E(1+2\kappa S_1^2)/E_x}$$

Ultimate compressive stress

Critical stress σ_{cr} at zero shear strain is determined by the following equation.

$$\sigma_{cr} = \alpha_c \cdot \frac{\pi}{4} (G_{eq} \cdot E_b)^{0.5} \cdot S_2$$

However, $E_b = E_{cr} [1 + 2/3 \cdot \kappa \cdot S_1^2] / [1 + E_{cr} (1 + 2/3 \cdot \kappa \cdot S_1^2) / E_x]$

[Note] S_1 is defined as 35.0 (for X0.4S, X0.6R) and 28.0 (for X0.3R) as standard value.

α_c : Correction factor determined from our test data

Rubber material X0.3R: $\alpha_c = 1.0$ (if $S_2 \geq 5$) $\alpha_c = (1 - 0.2 (5 - S_2))$ (if $5 > S_2$)

Rubber material X0.4S: $\alpha_c = 0.88$ (if $S_2 \geq 5$) $\alpha_c = 0.88 (1 - 0.07 (5 - S_2))$ (if $5 > S_2$)

Rubber material X0.6R: $\alpha_c = 1.45$ (if $S_2 \geq 5$) $\alpha_c = 1.45 - 0.3 (5 - S_2)$ (if $5 > S_2$)

$E_{CR} = 3 \times G_{eq}$ (for X0.4S, X0.6R) $E_{CR} = 2.2$ (for X0.3R)

Ultimate compressive stress at any shear strain $\sigma_{cr}'(\gamma)$ is determined by σ_{cr} by the following equation.

$$\sigma_{cr}'(\gamma) = \sigma_{cr} \cdot \left(1 - \frac{\gamma}{S_2}\right)$$

The ultimate compressive stress shall not exceed the upper limit σ_L determined as below and the strain region corresponding to the ultimate strain γ_L at 0 compressive stress.

Rubber material X0.3R: $\sigma_L = 40$ (if $S_2 \geq 5.0$) $\sigma_L = 40 + 10 (S_2 - 5)$ ($5.0 > S_2 \geq 3.0$)

γ_L is defined as minimum value among $\lceil 400\% \rceil$, $\lceil S_2 \times 0.9 \times 100\% \rceil$, $\lceil (5.80 \times S_2 + 7.10) / (S_2 + 3.45) \times 100\% \rceil$

Rubber material X0.4S: $\sigma_L = 45$ (if $S_2 \geq 4.9$) $\sigma_L = 45 + 10 (S_2 - 5)$ (if $4.9 > S_2 \geq 4.0$) $\sigma_L = 40 + 10 (S_2 - 5)$ (if $4.0 > S_2 \geq 3.0$)

γ_L is defined as minimum value among $\lceil 400\% \rceil$, $\lceil S_2 \times 0.9 \times 100\% \rceil$, $\lceil (5.80 \times S_2 + 9.05) / (S_2 + 4.49) \times 100\% \rceil$

Rubber material X0.6R: $\sigma_L = 60$ (if $S_2 \geq 4.9$) $\sigma_L = 48 + 14 (S_2 - 4)$ (if $4.9 > S_2 \geq 4.0$)

$\sigma_L = 24 + 24 (S_2 - 3)$ (if $4.0 > S_2 \geq 3.5$) $\sigma_L = 22 + 28 (S_2 - 3)$ (if $3.5 > S_2 \geq 3.0$)

γ_L is defined as minimum value among $\lceil 400\% \rceil$, $\lceil S_2 \times 0.9 \times 100\% \rceil$, $\lceil (5.00 \times S_2 + 9.05) / (S_2 + 4.49) \times 100\% \rceil$

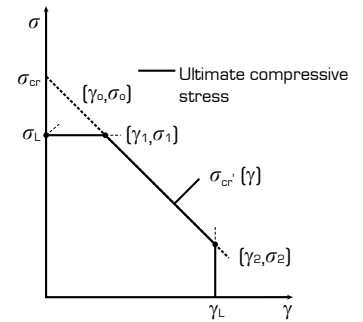

Lead Rubber Bearing (LRB)

Seismic isolation material certification number by Ministry of Land, Infrastructure and Transport, Japan
MVBR-0517
Acquired in December 2014

Product Dimension

Characteristics		Sectional View	
Physical Dimensions	Outer diameter	: D_o (mm)	
	Lead plug diameter	: D_i (mm)	
	Number of inner diameter	: $A_r \times 10^2$ (mm ²)	
	Effective plane area	: t_r (mm)	
	Thickness of one rubber layer	: n	
	Number of rubber layers	: $H = n \cdot t_r$ (mm)	
	First shape factor $S_1 = (D_o) / (4 \cdot t_r)$		
	Second shape factor $S_2 = D_o / (n \cdot t_r)$		
	Diameter of flange	: D_f (mm)	
	Thickness of flange: edge/center	: t_e / t_c (mm)	
	Connecting bolt PCD	: PCD (mm)	
	Diameter of connecting bolt hole \times qty	: d_b (mm) \times qty	
	Bolt size (assumption)	: $M (d_b - 3)$	
	Thickness of each reinforced steel plate	: t_s (mm)	
	Total height	: H_t (mm)	
Total weight 1 (kN) = 1/9.80665 (tonf)			

Rubber Material

Notation of rubber kind (standard temperature 20°C standard strain $\gamma = 100\%$)

Compound name	Rubber code	Shear modulus G_{eq} (N/mm ²)
G4	G0.4	0.385

Composition of rubber materials (weight ratio %)

Rubber code	Natural rubber Synthetic rubber	Filler; Reinforcement agent	Vulcanization agent and others
Inner rubber (G0.4)	60 and above	10 and above	25 and below
Cover rubber	40 and above	15 and above	40 and below

Properties of rubber materials

Item	Tensile strength (N/mm ²)	Elongation at Break (%)	Hardness (JIS A)	100% modulus (N/mm ²)	Young's modulus E (N/mm ²)	Bulk modulus E_v (N/mm ²)	Correction factor for apparent Young's modulus according to hardness, k
Test Standard	JIS K6251	JIS K6251	JIS K6253	JIS K6251	-	-	-
Inner rubber	17 and above	600 and above	37 \pm 5	0.8 \pm 0.2	2.20	1176	0.85
Cover rubber	12 and above	600 and above	-	-	-	-	-

Steel Material

Steel material for each part

	Material
Reinforced steel plate	SS400 (JIS G 3101)
Flange ^{*1,2}	SS400 (JIS G 3101)
Connecting plate ^{*1}	SS400 (JIS G 3101)
Lead plug	Pb (JIS H 2105 special)

*1: Optionally SM490A (JIS G 3106).

*2: Optionally special thickness other than standard thickness.

Anti-rust treatment of flange

Preparation	Remove rust up to blasting quality of SSPC-SP-10 (SIS Sa 2 1/2)
Primer	Zinc-rich paint. 75 μ m \times 1 coat
Middle coat	Epoxy resin paint. 60 μ m \times 1 coat
Finishing	Epoxy resin paint. 35 μ m \times 1 coat
Total film thickness	170 μ m and above

*1: Standard color is gray.

*2: Other kinds of anti-rust treatment are also available. Please contact us for more details.

Precautions

- Due to the lead plug embedded in the center of the laminated rubber body, special treatment is required in case the laminated rubber bearing is to be treated as industrial waste, depending on country. Please confirm with the country's regulation.
- For mid-storey isolation, fire resistant cover is necessary. Please check with fire resistant cover manufacturer who are listed in the JSSI manufacturer list for more details. (http://www.jssi.or.jp/business/kigyou_detail/to-si-base.htm)

Shear Properties

Equivalent shear stiffness K_{eq} , equivalent damping ratio H_{eq} , initial stiffness K_1 , post-yield stiffness K_2 , characteristic strength Q_d

Shear properties of LRB is dependent on shear strain amplitude.

The shear strain dependency of each property is expressed by the following equations.

Post-yield stiffness : $K_2 = K_d = C_{kd} \cdot (K_r + K_p)$
 Shear stiffness of laminated rubber : $K_r = G_r \cdot A_r / H$
 Additional shear stiffness by lead plug : $K_p = \alpha_p \cdot A_p / H$

Where, C_{kd} : post-yield stiffness correction factor due to strain dependency
 G_r : shear modulus of rubber 0.385N/mm²
 γ : shear strain
 α_p : apparent shear modulus of lead 0.583N/mm²

$$C_{kd} \begin{cases} 0.779 \gamma^{-0.43} [\gamma < 0.25] \\ \gamma^{-0.25} [0.25 \leq \gamma < 1.0] \\ \gamma^{-0.12} [1.0 \leq \gamma < 2.5] \end{cases}$$

Characteristics strength : $Q_d = C_{qd} \cdot \sigma_{pb} \cdot A_p$

Where, C_{qd} : characteristic strength correction factor due to strain dependency
 σ_{pb} : Shear stress at yield of lead 7.967N/mm²

$$C_{qd} \begin{cases} 2.036 \gamma^{0.41} [\gamma \leq 0.1] \\ 1.106 \gamma^{0.145} [0.1 < \gamma < 0.5] \\ 1 [0.5 \leq \gamma] \end{cases}$$

Initial stiffness : $K_1 = \beta \cdot K_d$

Where, β : Ratio of initial stiffness to post-yield stiffness which is between 10~15. (recommended value: 13)

Equivalent shear stiffness K_{eq} Equivalent damping ratio H_{eq}

$$K_{eq} = \frac{Q_d}{\gamma \cdot H} + K_d$$

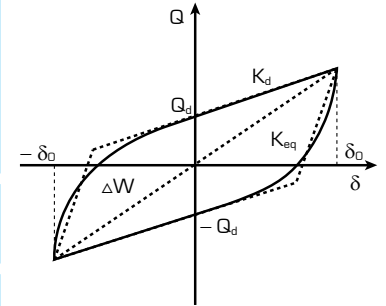
$$H_{eq} = \frac{2}{\pi} \cdot \frac{Q_d \left(\gamma \cdot H - \frac{Q_d}{(\beta - 1)K_d} \right)}{K_{eq} \cdot (\gamma \cdot H)^2}$$

Temperature dependency

Each shear properties shall be corrected to the value at standard temperature of 20°C by the following equations (Applicable range: $-20 \leq T \leq 40^\circ\text{C}$) (T: Temperature during inspection)

• Temperature correction equation : $K_d [T^\circ\text{C}] = K_d [\text{standard value at } 20^\circ\text{C}] \times [1.052 - 2.955 \times 10^{-3} \cdot T + 1.895 \times 10^{-5} \cdot T^2]$
 $Q_d [T^\circ\text{C}] = Q_d [\text{standard value at } 20^\circ\text{C}] \times [1.192 - 1.017 \times 10^{-2} \cdot T + 2.722 \times 10^{-5} \cdot T^2]$

• Standard value of temperature dependency Standard temperature (20°C)^{*1}

Properties values	-10°C	0°C	30°C	40°C
Post-yield stiffness K_d	+10%	+6%	-3%	-5%
Characteristic strength Q_d	+36%	+23%	-11%	-21%

*1 : The standard value takes into account the variation of 20% to the value obtained by the temperature correction equation.

Performance variation

The rate of change of main causes (manufacturing variation, aging, temperature change) which affect shear properties as shown below.

Rubber materials	GO.4		
Properties	Post-yield stiffness K_d	Characteristic strength Q_d	
Manufacturing variation ^{*2}	Within $\pm 10\%$	Within $\pm 10\%$	
Aging ^{*3}	Within +10%	-	
Ambient temperature variation 20°C \pm 20°C	(+) side	Within +6%	Within +23%
	(-) side	Within -5%	Within -21%
Total	(+) side	Within +26%	Within +33%
	(-) side	Within -15%	Within -31%

*2 : The variation of each product (standard value) shall be within $\pm 20\%$ and variation of total units of products per project (total of standard values) shall be within $\pm 10\%$.
 If total units per project are less than 8 units, variation of total units of products per project (total of standard values) shall be within $\pm 15\%$.
 *3 : Predicted rate of change after 60 years at 20°C standard temperature. (20% variation is considered in the rate of change)
 *4 : Above list shows the combination example.

Compressive Properties

Compressive stiffness K_v

• Compressive stiffness K_v is determined by the following equation.

$$K_v = \alpha_v \cdot E_c \cdot \frac{A}{H} \quad E_c = \frac{E(1+2\kappa S_1^2)}{1+E(1+2\kappa S_1^2)/E_c}$$

A : Laminated rubber plane area A : Effective plane area A_p : Lead plug plane area
 A = A_r + A_p
 α_v : Young's modulus correction factor = 1.23

Ultimate compressive stress (refer the figure on the right)

• Critical stress σ_{cr} at zero shear strain is determined by the following equation.

$$\sigma_{cr} = \frac{\pi}{4} \cdot 1.26 \cdot \alpha_c \cdot (G_{eq} \cdot E_b)^{0.5} \cdot S_2$$

However, $E_b = E [1 + 2/3 \cdot \kappa \cdot S_1^2] / [1 + E(1 + 2/3 \cdot \kappa \cdot S_1^2) / E_c]$

α_c : Correction factor based on S_2 determined from our test data

If $S_2 \geq 5$: $\alpha_c = 1$, if $S_2 < 5$: $\alpha_c = 0.25 \cdot (S_2 - 5) + 1$

• Ultimate compressive stress at any shear strain $\sigma_{cr}(\gamma)$ is determined by σ_{cr} by the following equation.

$$\sigma_{cr}(\gamma) = \sigma_{cr} \cdot (1 - 0.9 \frac{\gamma}{S_2})$$

• The ultimate compressive stress shall not exceed the upper limit σ_L determined as below and the strain region corresponding to the ultimate strain γ_L at 0 compressive stress.

$$\sigma_L = 60 \text{ [N/mm}^2\text{]} \\ \gamma_L = \min [400\%, S_2 \times 100\%]$$

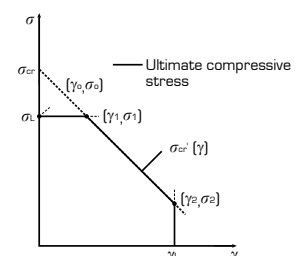
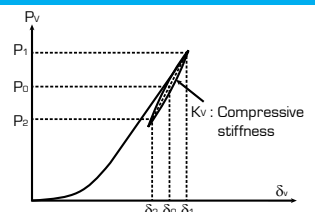

Natural Rubber Bearing (NRB)

Seismic isolation material certification number by Ministry of Land, Infrastructure and Transport, Japan
MVBR-0295 (N3, G3, G5)
MVBR-0509/MVBR-0518 (G4)
 Acquired in January 2006
 Acquired in December 2014

Product Dimension

Characteristics		Sectional View
Physical Dimensions	Outer diameter	: D_o (mm)
	Inner diameter	: D_i (mm)
	Number of inner diameter	: n_i
	Effective plane area	: A ($\times 10^2 \text{mm}^2$)
	Thickness of one rubber layer	: t_r (mm)
	Number of rubber layers	: n
	Total rubber thickness	: $H = n \times t_r$ (mm)
	First shape factor $S_1 = (D_o^2 - n_i \cdot D_i^2) / \{4 \cdot t_r \cdot (D_o + n_i \cdot D_i)\}$	
	Second shape factor $S_2 = D_o / (n \cdot t_r)$	
	Diameter of flange	: D_f (mm)
	Thickness of flange: edge/center	: t_e/t_c (mm)
	Connecting bolt PCD	: PCD (mm)
	Diameter of connecting bolt hole \times qty	: d_b (mm) \times qty
	Bolt size [assumption]	: M ($d_b - 3$)
	Thickness of each reinforced steel plate	: t_s (mm)
	Total height	: H_t (mm)
	Total weight 1 (kN) = 1/9.80665 (tonf)	

Integrated Type Flange

Assembled Type Flange

Rubber Material

Notation of rubber kind (standard temperature 20°C standard strain $\gamma = 100\%$)

Compound name	Rubber code	Shear modulus G_{eq} (N/mm ²)
N3	G0.30	0.294
G3	G0.35	0.343
G4	G0.40	0.392
G5	G0.45	0.441

Composition of rubber materials (weight ratio %)

Rubber code	Natural rubber Synthetic rubber	Filler, Reinforcement agent	Vulcanization agent and others
Inner rubber	G0.30	55 and above	15 and above 25 and below
	G0.35	60 and above	10 and above 25 and below
	G0.40	60 and above	10 and above 25 and below
	G0.45	65 and above	10 and above 20 and below
Cover rubber	40 and above	15 and above	40 and below

Properties of rubber materials

Item	Tensile strength (N/mm ²)	Elongation at Break (%)	Hardness (JIS A)	100% modulus (N/mm ²)	Young's modulus E (N/mm ²)	Bulk modulus E_v (N/mm ²)	Correction factor for apparent Young's modulus according to hardness, k
Test Standard	JIS K6251	JIS K6251	JIS K6253	JIS K6251	-	-	-
Inner rubber	G0.30	14 and above	600 and above	33 \pm 4	0.6 \pm 0.2	1.64	1200 0.85
	G0.35	16 and above	600 and above	33 \pm 4	0.7 \pm 0.2	1.92	1200 0.85
	G0.40	17 and above	600 and above	37 \pm 5	0.8 \pm 0.2	2.20	1200 0.85
	G0.45	17 and above	600 and above	40 \pm 5	0.9 \pm 0.2	2.47	1300 0.85
Cover rubber	12 and above	600 and above	-	-	-	-	-

Steel Material

Steel material for each part

Part	Material
Reinforced steel plate	SS400 (JIS G 3101)
Flange ^{*1,*2}	SS400 (JIS G 3101)
Connecting plate ^{*1}	SS400 (JIS G 3101)

*1: Optionally SM490A (JIS G 3106).

*2: Optionally special thickness other than standard thickness.

Anti-rust treatment of flange

Preparation	Remove rust up to blasting quality of SSPC-SP-10 (SIS Sa 2 1/2)
Primer	Zinc-rich paint 75 μ m \times 1 coat
Middle coat	Epoxy resin paint 60 μ m \times 1 coat
Finishing	Epoxy resin paint 35 μ m \times 1 coat
Total film thickness	170 μ m and above

*1: Standard color is gray.

*2: Other kinds of anti-rust treatment are also available. Please contact us for more details.

Precautions

- For mid-storey isolation, fire resistant cover is necessary. Please contact fire resistant cover manufacturer who are listed in the JSSI manufacturer list for more details. (http://www.jssi.or.jp/bussiness/kigyuu_detail/to-si-base.htm)
- There are two certification numbers for G0.40 due to difference of some manufacturing process. Although their properties values are the same, please fill the certification number as shown in the table on the right in the design documents.

Rubber size ϕ 1000 and below	Rubber size ϕ 1100 and above
Both MVBR-0509/MVBR-0518	MVBR-0509 only

Shear Properties

Shear stiffness K_h

NRB shows linear restoring force characteristics in horizontal direction.

Shear stiffness K_h is expressed by the following equation.

$$K_h = \frac{G_{eq} \cdot A}{H}$$

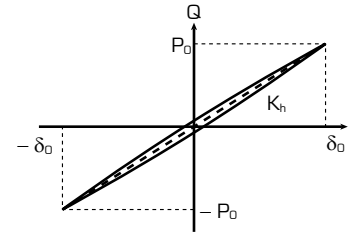

δ_0 : Displacement equivalent to 100% strain
 P_0 : Maximum load
 K_h : Shear stiffness (secant stiffness)
 G_{eq} : Shear modulus

Temperature dependency

Shear stiffness shall be corrected to the value at standard temperature of 20°C by the following equation.

(Applicable: $-10 \leq T \leq 40^\circ\text{C}$) (T: Temperature during inspection)

● Temperature correction equation :

$$K_h (T^\circ\text{C}) = K_h (\text{standard value at } 20^\circ\text{C}) \times (1.052 - 2.955 \times 10^{-3} \cdot T + 1.895 \times 10^{-5} \cdot T^2)$$

(Applied to all rubber codes)

● Standard value of temperature dependency Standard temperature (20°C)^{*1}

Properties values	-10°C	0°C	30°C	40°C
Shear stiffness K_h	+8%	+6%	-3%	-5%

*1 : The standard value takes into account the variation of 20% to the value obtained by the temperature correction equation.

Performance variation

The rate of change of main causes (manufacturing variation, aging, temperature change) which affect shear properties as shown below.

Rubber materials	Common
Properties	Shear stiffness K_h
Manufacturing variation ^{*2}	Within $\pm 10\%$
Aging ^{*3}	Within +10%
Ambient temperature variation $20^\circ\text{C} \pm 20^\circ\text{C}$	(+) side Within +6% (-) side Within -5%
Total	(+) side Within +26% (-) side Within -15%

*2 : The variation of each product (standard value) shall be within $\pm 20\%$ and variation of total units of products per project (total of standard values) shall be within $\pm 10\%$. However, if the total units of products is less than 8 units per project, the variation (total of standard values) shall be within $\pm 15\%$.

(Note: For compressive stiffness K_v , variation of each product (standard value) shall be within $\pm 20\%$.)

*3 : Predicted rate of change after 60 years at 20°C standard temperature.
 [20% variation is considered in the rate of change]

Compressive Properties

Compressive stiffness K_v

● Compressive stiffness K_v is determined by the following equation.

$$K_v = E_c \cdot \frac{A}{H} \quad E_c = \frac{E(1+2\kappa S_1^2)}{1+E(1+2\kappa S_1^2)/E_\infty}$$

Ultimate compressive stress (refer the figure on the right)

● Critical stress σ_{cr} at zero shear strain is determined by the following equation.

$$\sigma_{cr} = \pi/4 \cdot \alpha_c \cdot (G_{eq} \cdot E_b)^{0.5} \cdot S_2$$

However, $E_b = E(1+2/3 \cdot \kappa \cdot S_1^2) / \{1 + E(1+2/3 \cdot \kappa \cdot S_1^2) / E_\infty\}$

α_c : Correction factor based on S_2 determined from our test data

If $S_2 \geq 5$: $\alpha_c = 1.0$, if $S_2 < 5$: $\alpha_c = 0.10 \cdot (S_2 - 5) + 1$

● Ultimate compressive stress at any shear strain $\sigma_{cr}'(\gamma)$ is determined by σ_{cr} by the following equation.

$$\sigma_{cr}'(\gamma) = \sigma_{cr} \cdot [1 - \beta_c \cdot \gamma / S_2]$$

β_c : Correction factor based on S_2 determined from our test data

If $S_2 \geq 5$: $\beta_c = 0.76$, if $S_2 < 5$: $\beta_c = 0.76 / \{0.15 \cdot (S_2 - 5) + 1\}$

● The ultimate compressive stress shall not exceed the upper limit σ_L determined as below and the strain region corresponding to the ultimate strain γ_L at 0 compressive stress.

Rubber materials GO.30, GO.35 : $\sigma_L = 40$ [N/mm²]

Rubber materials GO.40, GO.45 : $\sigma_L = 60$ [N/mm²]

$\gamma_L = \min(400\%, S_2 \times 100\%)$

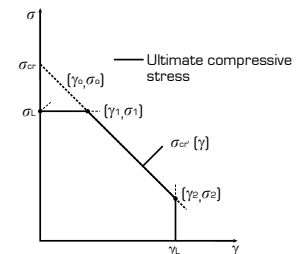
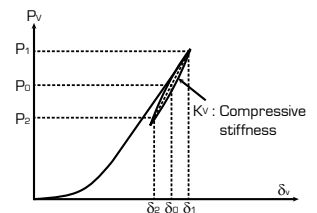

● Shear Properties

■ Initial stiffness K_1

Initial stiffness K_1 of elastic sliding bearing is expressed by the following equation.

$$K_1 = \frac{G_{eq} \cdot A}{H}$$

Effective plane area A [mm²]
Total rubber thickness H [mm]

Shear modulus in the above equation takes the values below.

	SL series
Shear modulus G_{eq} [N/mm ²]	1.18

■ Friction coefficient μ

Compressive stress dependency and velocity dependency of the friction coefficient μ are expressed by the following equations.

SL series ($\mu = 0.13, G1.2$)
$\mu = (0.112 - 0.00276 \cdot \sigma) \cdot V^{0.0863}$

σ [N/mm²] is the compressive stress applied on sliding material; V [mm/s] is the sliding velocity.

The standard compressive stress is $\sigma = 10$ N/mm² (for SL series), while the standard velocity is $V = 100$ mm/s.

■ Temperature dependency of initial stiffness

Initial stiffness shall be corrected to the value at standard temperature of 20°C.

(Applicable: $-10 \leq T \leq 40^\circ\text{C}$) (T: Temperature during inspection)

● Standard value of temperature dependency Standard temperature [20°C]

Properties values		-10°C	0°C	30°C	40°C
Initial stiffness	SL series	within +14%	within +9%	within -4%	within -8%

*1 : 20% variation is considered in the rate of change.

■ Performance variation

The rate of change of main causes (manufacturing variation, aging, temperature change) which affect shear properties shall be shown as below.

Series		SL Series	
Properties		Initial stiffness K_1	Friction coefficient μ
Manufacturing variation ^{*2}		Within $\pm 30\%$	Within $\pm 20\%$
Aging ^{*3}		Within +16%	-
Ambient temperature variation 20°C \pm 20°C	(+) side	Within +9%	-
	(-) side	Within -8%	-
Total	(+) side	Within +55%	Within +20%
	(-) side	Within -38%	Within -20%

*2 : The variation for both friction coefficient μ and initial stiffness K_1 of each product (standard value) shall be within the required variation range.
(Note: For compressive stiffness K_v , variation of each product (standard value) shall be within $\pm 20\%$ for SL series.)

*3 : Predicted rate of change after 60 years at 20°C standard temperature.
(20% variation is considered in the rate of change.)

*4 : Above list shows the combination example.

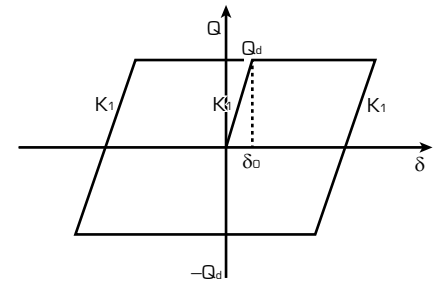

μ : Friction coefficient
 P_v : Vertical load
 K_1 : Initial stiffness
 δ : Horizontal deformation
 Q_d : Yield load (characteristic strength)

● Compressive Properties

■ Compressive stiffness K_v

● Compressive stiffness K_v is determined by the following equation.

$$K_v = \alpha_v \cdot E_c \cdot \frac{A}{H} \quad E_c = \frac{E(1+2\kappa S_1^2)}{1+E(1+2\kappa S_1^2)/E_\infty}$$

(SL series) α_v : 1.0

■ Ultimate compressive stress (refer the figure on the right)

● Since bearings will slide before reaching to the buckling shear strain γ_L , ultimate compressive stress takes constant value as below regardless of the deformation of bearings.

For SL series : $\sigma_L = 50$ [N/mm²]

● The ultimate deformation shall be determined by the relationship between bearing diameter and sliding plate dimension.

The upper limit of SL series is 700mm.

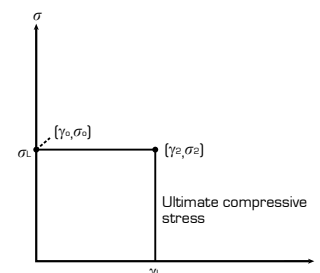
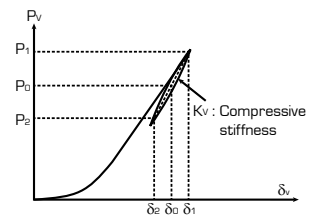

Product Specification

(Please contact us if you require more information regarding the specification)

High Damping Rubber Bearing (HDR)

Certification Number MVBR-0516 (X0.3R)

Code

Compound name	Rubber code	Shear modulus [N/mm ²]	Equivalent damping ratio
X3R	X0.3R	0.300	0.170

●HM Series (Total Rubber Thickness 16cm)

Characteristics		HM060X3R	HM070X3R	HM080X3R	
Physical Dimensions	Outer diameter (mm)	600	700	800	
	Inner diameter (mm)	15	15	20	
	Effective plane area (×10 ² mm ²)	2826	3847	5023	
	Thickness of one rubber layer (mm)	5.0	5.9	6.8	
	Number of rubber layers (-)	32	27	23	
	Total rubber thickness (mm)	160.0	159.3	156.4	
	First shape factor (-)	29.3	29.0	28.7	
	Second shape factor (-)	3.75	4.39	5.12	
	Diameter of flange (mm)	800	900	1000	
	Thickness of flange ^{*1} (mm)	19	19	19	
	Connecting bolt PCD (mm)	825	925	1025	
	Diameter of connecting bolt hole × qty (mm)	∅ 33 × 8	∅ 33 × 8	∅ 33 × 8	
	Bolt size (assumption) (-)	M30	M30	M30	
	Thickness of each reinforced steel plate (mm)	3.1	3.1	3.1	
	Total height (mm)	294.1	277.9	262.6	
	Total weight (tonf)	0.44	0.54	0.64	
Total weight (kN)	4.4	5.3	6.3		
Compression Properties	Critical stress [N/mm ²]	σ_{cr} when $\gamma = 0$	28	34	40
	Ultimate compressive stress [N/mm ²]	(γ_{cr}, σ_c)	(0.00,28)	(0.00,34)	(0.00,40)
		(γ_{1}, σ_1)	(0.20,28)	(0.65,34)	(1.24,40)
		(γ_{2}, σ_2)	(3.38,3)	(3.95,4)	(4.00,12)
	Compressive stiffness (×10 ³ kN/m)		1740	2370	3140
	Nominal long term compressive stress ^{*2} [N/mm ²]		5.0	5.0	5.0
	Nominal long term column load (kN)		1410	1920	2510
Allowable tensile stress [N/mm ²]		1.0	1.0	1.0	
Shear Properties ($\gamma = 100\%$)	Initial stiffness (×10 ³ kN/m)		3.82	5.22	6.95
	Post yield stiffness (×10 ³ kN/m)		0.382	0.522	0.695
	Characteristic Strength (kN)		23.7	32.2	42.0
	Equivalent shear stiffness (×10 ³ kN/m)		0.530	0.724	0.964
	Equivalent damping ratio (-)		0.170	0.170	0.170

*1 Special thickness for flange is available. Please contact us for more details.

*2 Nominal long term compressive stress is referred as long term upper limit of compressive stress.

Description of the product designation

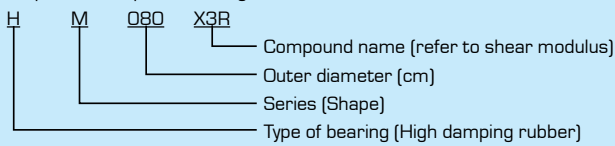

Certification Number MVBR-0516 (X0.3R)

Code

Compound name	Rubber code	Shear modulus [N/mm ²]	Equivalent damping ratio
X3R	X0.3R	0.300	0.170

●HN Series (Total Rubber Thickness 20cm)

Characteristics		HN060X3R	HN070X3R	HN080X3R	
Physical Dimensions	Outer diameter (mm)	600	700	800	
	Inner diameter (mm)	15	15	20	
	Effective plane area (×10 ² mm ²)	2826	3847	5023	
	Thickness of one rubber layer (mm)	5.0	5.9	6.8	
	Number of rubber layers (-)	40	34	29	
	Total rubber thickness (mm)	200.0	200.6	197.2	
	First shape factor (-)	29.3	29.0	28.7	
	Second shape factor (-)	3.00	3.49	4.06	
	Diameter of flange (mm)	800	900	1000	
	Thickness of flange*1 (mm)	19	19	19	
	Connecting bolt PCD (mm)	825	925	1025	
	Diameter of connecting bolt hole × qty (mm)	∅ 33 × 8	∅ 33 × 8	∅ 33 × 8	
	Bolt size (assumption) (-)	M30	M30	M30	
	Thickness of each reinforced steel plate (mm)	3.1	3.1	3.1	
	Total height (mm)	358.9	340.9	322.0	
	Total weight (tonf)	0.51	0.62	0.74	
Total weight (kN)	5.0	6.1	7.2		
Compression Properties	Critical stress [N/mm ²]	σ_{cr} when $\gamma = 0$	19	25	31
	Ultimate compressive stress [N/mm ²]	(γ_0, σ_0)	(0.00,19)	(0.00,25)	(0.00,31)
		(γ_1, σ_1)	-	(0.03,25)	(0.41,31)
		(γ_2, σ_2)	(2.70,2)	(3.14,3)	(3.65,3)
	Compressive stiffness (×10 ³ kN/m)		1390	1880	2490
	Nominal long term compressive stress*2 [N/mm ²]		5.0	5.0	5.0
	Nominal long term column load (kN)		1410	1920	2510
Allowable tensile stress [N/mm ²]		1.0	1.0	1.0	
Shear Properties ($\gamma = 100\%$)	Initial stiffness (×10 ³ kN/m)		3.06	4.15	5.51
	Post yield stiffness (×10 ³ kN/m)		0.306	0.415	0.551
	Characteristic Strength (kN)		23.7	32.2	42.0
	Equivalent shear stiffness (×10 ³ kN/m)		0.424	0.575	0.764
	Equivalent damping ratio (-)		0.170	0.170	0.170

*1 Special thickness for flange is available. Please contact us for more details.

*2 Nominal long term compressive stress is referred as long term upper limit of compressive stress.

High Damping Rubber Bearing (HDR)

MVBR-0510/MVBR-0519 (X0.4S)

Note: There are 2 certification numbers due to difference of some manufacturing process.
Please refer to "Precautions" in page 6 for the certificate number that used for design document.

Code

Compound name	Rubber code	Shear modulus [N/mm ²]	Equivalent damping ratio
X4S	X0.4S	0.392	0.240

●HH Series (Total Rubber Thickness 20cm)

Characteristics		HH060X4S	HH065X4S	HH070X4S	HH075X4S	HH080X4S	HH085X4S	HH090X4S	HH095X4S	HH100X4S	HH110X4S	HH120X4S	HH130X4S	HH140X4S	HH150X4S	HH160X4S	
Physical Dimensions	Outer diameter (mm)	600	650	700	750	800	850	900	950	1000	1100	1200	1300	1400	1500	1600	
	Inner diameter (mm)	15	15	15	15	20	20	20	20	25	55	55	55	65	65	80	
	Effective plane area (×10 ² mm ²)	2826	3317	3847	4416	5023	5671	6359	7085	7849	9480	11286	13249	15361	17638	20056	
	Thickness of one rubber layer (mm)	4.0	4.4	4.7	5.0	5.4	5.7	6.0	6.4	6.7	7.4	8.0	8.7	9.5	10.0	10.4	
	Number of rubber layers (-)	50	45	43	40	37	35	33	31	30	27	25	23	21	20	19	
	Total rubber thickness (mm)	200	198	202	200	200	200	198	198	201	200	200	200	200	200	200	198
	First shape factor (-)	36.6	36.1	36.4	36.8	36.1	36.4	36.7	36.3	36.4	35.3	35.8	35.8	35.1	35.9	36.5	
	Second shape factor (-)	3.00	3.28	3.46	3.75	4.00	4.26	4.55	4.79	4.98	5.51	6.00	6.50	7.02	7.50	8.10	
	Diameter of flange (mm)	900	950	1000	1100	1150	1200	1250	1300	1400	1500	1600	1700	1800	1900	2000	
	Thickness of flange ^{*1} (edge/center) (mm)	22/28	22/28	22/28	22/28	24/32	24/32	28/36	28/36	28/36	30/38	32/40	32/40	37/45	42/50	50/110	
	Connecting bolt PCD (mm)	775	825	875	950	1000	1050	1100	1150	1250	1350	1450	1550	1650	1750	1800	
	Diameter of connecting bolt hole × qty (mm)	∅33 × 12	∅33 × 12	∅33 × 12	∅33 × 12	∅33 × 12	∅33 × 12	∅33 × 12	∅33 × 12	∅33 × 12	∅39 × 12	∅39 × 12	∅39 × 12	∅39 × 12	∅42 × 12	∅42 × 16	∅45 × 12
	Bolt size (assumption) (-)	M30	M30	M30	M30	M30	M30	M30	M30	M30	M36	M36	M36	M36	M39	M39	M42
	Thickness of each reinforced steel plate (mm)	3.1	3.1	3.1	3.1	4.4	4.4	4.4	4.4	4.4	4.4	4.4	4.4	4.4	5.8	5.8	5.8
	Total height (mm)	407.9	390.4	388.3	376.9	422.2	413.1	410.8	402.4	400.6	390.2	385.6	376.9	405.5	410.2	522.0	
	Total weight (tonf)	0.66	0.72	0.80	0.90	1.21	1.31	1.49	1.59	1.77	2.05	2.38	2.65	3.46	4.05	6.64	
Total weight (kN)	6.5	7.0	7.9	8.9	11.9	12.9	14.6	15.6	17.3	20.1	23.3	26.0	33.9	39.7	65.1		
Compression Properties	Critical stress [N/mm ²]	σ_{cr} when $\gamma = 0$	26	29	31	35	38	41	45	48	51	56	61	66	71	76	82
	Ultimate compressive stress [N/mm ²]	$(\gamma_{0r}, \sigma_{0r})$	(0,20)	(0,23)	(0,25)	(0,28)	(0,35)	(0,38)	(0,40)	(0,43)	(0,45)	(0,45)	(0,45)	(0,45)	(0,45)	(0,45)	(0,45)
		$(\gamma_{1r}, \sigma_{1r})$	(0,720)	(0,723)	(0,825)	(0,828)	(0,335)	(0,438)	(0,440)	(0,543)	(0,545)	(1,145)	(1,645)	(2,145)	(2,645)	(3,145)	(3,745)
		$(\gamma_{2r}, \sigma_{2r})$	(2,73)	(3,03)	(3,13)	(3,43)	(3,64)	(3,84)	(3,96)	(4,08)	(4,010)	(4,015)	(4,020)	(4,025)	(4,031)	(4,036)	(4,042)
	Compressive stiffness	(×10 ³ kN/m)	1700	2020	2290	2660	3030	3420	3870	4300	4700	5690	6780	7960	9230	10600	12200
	Nominal long term compressive stress ^{*2} [N/mm ²]		4.6	5.5	6.1	7.0	9.4	10.4	11.5	12.4	13.0	13.0	13.0	13.0	13.0	13.0	13.0
	Nominal long term column load (kN)		1300	1830	2340	3090	4710	5880	7280	8780	10200	12300	14700	17200	20000	22900	26100
Allowable tensile stress ($\gamma = 100\%$) [N/mm ²]		1.0	1.0	1.0	1.0	1.0	1.0	1.0	1.0	1.0	1.0	1.0	1.0	1.0	1.0	1.0	
Shear Properties ($\gamma = 100\%$)	Initial stiffness (×10 ³ kN/m)		3.28	3.89	4.42	5.12	5.83	6.60	7.45	8.29	9.06	11.0	13.1	15.4	17.9	20.5	23.6
	Post yield stiffness ($\gamma = 100\%$) (×10 ³ kN/m)		0.328	0.389	0.442	0.512	0.583	0.660	0.745	0.829	0.906	1.10	1.31	1.54	1.79	2.05	2.36
	Characteristic Strength (kN)		45.2	53.0	61.5	70.6	80.3	90.7	102	113	126	152	181	212	246	282	321
	Equivalent shear stiffness (×10 ³ kN/m)		0.554	0.657	0.746	0.866	0.986	1.11	1.26	1.40	1.53	1.86	2.21	2.60	3.02	3.46	3.98
	Equivalent damping ratio (-)		0.240	0.240	0.240	0.240	0.240	0.240	0.240	0.240	0.240	0.240	0.240	0.240	0.240	0.240	0.240

*1 Special thickness for flange is available. Please refer to the table on the next page (upper top table) for more details.

*2 Nominal long term compressive stress is referred as long term upper limit of compressive stress.

Specification of flange (edge thickness / center thickness)

Outer diameter of rubber bearing (Ø) ^{*1}	(600)	(650)	700	750	800	850	900	950	1000	1100	1200	1300				
Standard thickness	22/28	22/28	22/28	22/28	24/32	24/32	28/36	28/36	28/36	30/38	32/40	32/40				
Special thickness (option)	[26/32]	[26/32]	26/32	30/36	32/40	32/40	37/45	37/45	42/50	42/50	42/50	42/50				

×1 For adoption of special thickness in regard to those sizes that stated in the (), delivery time will be longer due to mold preparation.
 ×2 For Ø1400 and above, assembled type flange will be used.
 ×3 Compared to the standard specification, total height & weight of product for special thickness will be changed.

MVBR-0514/MVBR-0520 (X0.6R)

Note: There are 2 certification numbers due to difference of some manufacturing process.
 Please refer to "Precautions" in page 6 for the certificate number that used for design document.

Code

Compound name	Rubber code	Shear modulus (N/mm ²)	Equivalent damping ratio
X6R	X0.6R	0.620	0.240

●HH Series (Total Rubber Thickness 20cm)

Characteristics		HH060X6R	HH065X6R	HH070X6R	HH075X6R	HH080X6R	HH085X6R	HH090X6R	HH095X6R	HH100X6R	HH110X6R	HH120X6R	HH130X6R	HH140X6R	HH150X6R	HH160X6R	
Physical Dimensions	Outer diameter (mm)	600	650	700	750	800	850	900	950	1000	1100	1200	1300	1400	1500	1600	
	Inner diameter (mm)	15	15	15	15	20	20	20	20	25	55	55	55	65	65	80	
	Effective plane area (×10 ² mm ²)	2826	3317	3847	4416	5023	5671	6359	7085	7849	9480	11286	13249	15361	17638	20056	
	Thickness of one rubber layer (mm)	4.0	4.4	4.7	5.0	5.4	5.7	6.0	6.4	6.7	7.4	8.0	8.7	9.5	10.0	10.4	
	Number of rubber layers (-)	50	45	43	40	37	35	33	31	30	27	25	23	21	20	19	
	Total rubber thickness (mm)	200	198	202	200	200	200	198	198	201	200	200	200	200	200	200	198
	First shape factor (-)	36.6	36.1	36.4	36.8	36.1	36.4	36.7	36.3	36.4	35.3	35.8	35.8	35.1	35.9	36.5	
	Second shape factor (-)	3.00	3.28	3.46	3.75	4.00	4.26	4.55	4.79	4.98	5.51	6.00	6.50	7.02	7.50	8.10	
	Diameter of flange (mm)	900	950	1000	1100	1150	1200	1250	1300	1400	1500	1600	1700	1800	1900	2000	
	Thickness of flange ^{*1} (edge/center) (mm)	22/28	22/28	22/28	22/28	24/32	24/32	28/36	28/36	28/36	30/38	32/40	32/40	37/45	42/50	50/110	
	Connecting bolt PCD (mm)	775	825	875	950	1000	1050	1100	1150	1250	1350	1450	1550	1650	1750	1800	
	Diameter of connecting bolt hole × qty (mm)	Ø33×12	Ø33×12	Ø33×12	Ø33×12	Ø33×12	Ø33×12	Ø33×12	Ø33×12	Ø33×12	Ø39×12	Ø39×12	Ø39×12	Ø39×12	Ø42×12	Ø42×16	Ø45×12
	Bolt size (assumption) (-)	M30	M30	M30	M30	M30	M30	M30	M30	M30	M36	M36	M36	M36	M39	M39	M42
	Thickness of each reinforced steel plate (mm)	3.1	3.1	3.1	3.1	4.4	4.4	4.4	4.4	4.4	4.4	4.4	4.4	5.8	5.8	5.8	
	Total height (mm)	407.9	390.4	388.3	376.9	422.2	413.1	410.8	402.4	400.6	390.2	385.6	376.9	405.5	410.2	522.0	
	Total weight (tonf)	0.66	0.72	0.80	0.90	1.21	1.31	1.49	1.59	1.77	2.05	2.38	2.65	3.46	4.05	6.64	
Total weight (kN)	6.5	7.0	7.9	8.9	11.9	12.9	14.6	15.6	17.3	20.1	23.3	26.0	33.9	39.7	65.1		
Compression Properties	Critical stress (N/mm ²)	σ_{cr} when $\gamma = 0$	43	52	58	69	78	89	102	113	122	136	148	160	173	185	200
	Ultimate compressive stress (N/mm ²)	(γ'_0, σ_0)	(0,22)	(0,30)	(0,35)	(0,42)	(0,48)	(0,52)	(0,56)	(0,59)	(0,60)	(0,60)	(0,60)	(0,60)	(0,60)	(0,60)	(0,60)
		(γ'_1, σ_1)	(15,22)	(14,30)	(14,35)	(15,42)	(16,48)	(18,52)	(21,56)	(23,59)	(25,60)	(31,60)	(36,60)	(38,60)	(38,60)	(39,60)	(39,60)
		(γ'_2, σ_2)	(2,74)	(3,05)	(3,16)	(3,47)	(3,411)	(3,517)	(3,523)	(3,629)	(3,634)	(3,746)	(3,756)	-	-	-	-
	Compressive stiffness (×10 ³ kN/m)		1970	2340	2660	3090	3510	3970	4490	4980	5450	6590	7860	9220	10700	12300	14200
	Nominal long term compressive stress (N/mm ²)		6.6	8.1	9.1	10.7	12.0	13.4	15.0	15.0	15.0	15.0	15.0	15.0	15.0	15.0	15.0
Nominal long term column load (kN)		1860	2690	3500	4710	6050	7620	9540	10600	11800	14200	16900	19900	23000	26500	30100	
Allowable tensile stress ($\gamma = 100\%$) (N/mm ²)		1.0	1.0	1.0	1.0	1.0	1.0	1.0	1.0	1.0	1.0	1.0	1.0	1.0	1.0	1.0	
Shear Properties ($\gamma = 100\%$)	Initial stiffness (×10 ³ kN/m)		5.19	6.15	6.99	8.10	9.23	10.4	11.8	13.1	14.3	17.4	20.7	24.3	28.3	32.4	37.3
	Post yield stiffness ($\gamma = 100\%$) (×10 ³ kN/m)		0.519	0.615	0.699	0.810	0.923	1.04	1.18	1.31	1.43	1.74	2.07	2.43	2.83	3.24	3.73
	Characteristic Strength (kN)		71.5	83.9	97.3	112	127	143	161	179	199	240	285	335	389	446	507
	Equivalent shear stiffness (×10 ³ kN/m)		0.876	1.04	1.18	1.37	1.56	1.76	1.99	2.21	2.42	2.94	3.50	4.11	4.77	5.47	6.29
	Equivalent damping ratio (-)		0.240	0.240	0.240	0.240	0.240	0.240	0.240	0.240	0.240	0.240	0.240	0.240	0.240	0.240	0.240

×1 Special thickness for flange is available. Please refer to the table above for more details.

MVBR-0510/MVBR-0519 (X0.4S)

Note: There are 2 certification numbers due to difference of some manufacturing process.
Please refer to "Precautions" in page 6 for the certificate number that used for design document.

Code

Compound name	Rubber code	Shear modulus [N/mm ²]	Equivalent damping ratio
X4S	X0.4S	0.392	0.240

●HL Series (Total Rubber Thickness 16cm)

Characteristics		HLO60X4S	HLO65X4S	HLO70X4S	HLO75X4S	HLO80X4S	HLO85X4S	HLO90X4S	HLO95X4S	HL100X4S	HL110X4S	HL120X4S	HL130X4S	
Physical Dimensions	Outer diameter (mm)	600	650	700	750	800	850	900	950	1000	1100	1200	1300	
	Inner diameter (mm)	15	15	15	15	20	20	20	20	25	55	55	55	
	Effective plane area (×10 ² mm ²)	2826	3317	3847	4416	5023	5671	6359	7085	7849	9480	11286	13249	
	Thickness of one rubber layer (mm)	3.95	4.4	4.9	4.85	5.1	5.25	5.65	6.00	6.35	7.2	7.7	8.0	
	Number of rubber layers (-)	41	37	34	34	33	32	30	28	26	23	22	21	
	Total rubber thickness (mm)	162	163	167	165	168	168	170	168	165	166	169	168	
	First shape factor (-)	37.0	36.1	34.9	37.9	38.2	39.5	38.9	38.8	38.4	36.3	37.2	38.9	
	Second shape factor (-)	3.70	3.99	4.20	4.55	4.75	5.06	5.31	5.65	6.06	6.64	7.08	7.74	
	Diameter of flange (mm)	900	950	1000	1100	1150	1200	1250	1300	1400	1500	1600	1700	
	Thickness of flange (edge/center) (mm)	22/28	22/28	22/28	22/28	24/32	24/32	28/36	28/36	28/36	30/38	32/40	32/40	
	Connecting bolt PCD (mm)	775	825	875	950	1000	1050	1100	1150	1250	1350	1450	1550	
	Diameter of connecting bolt hole × qty (mm)	∅33 × 12	∅33 × 12	∅33 × 12	∅33 × 12	∅33 × 12	∅33 × 12	∅33 × 12	∅33 × 12	∅39 × 12	∅39 × 12	∅39 × 12	∅39 × 12	
	Bolt size (assumption) (-)	M30	M30	M30	M30	M30	M30	M30	M30	M36	M36	M36	M36	
	Thickness of each reinforced steel plate (mm)	3.1	3.1	3.1	3.1	4.4	4.4	4.4	4.4	4.4	4.4	4.4	5.8	
	Total height (mm)	342.0	330.4	324.9	323.2	373.1	368.4	369.1	358.8	347.1	338.4	341.8	364.0	
	Total weight (tonf)	0.58	0.64	0.70	0.82	1.12	1.23	1.40	1.49	1.63	1.88	2.22	2.80	
Total weight (kN)	5.7	6.3	6.9	8.1	11.0	12.1	13.7	14.6	15.9	18.4	21.8	27.5		
Compression Properties	Critical stress [N/mm ²]	σ_{cr} when $\gamma = 0$	34	38	40	45	48	51	54	58	62	68	79	
	Ultimate compressive stress [N/mm ²]	$(\gamma_{cr}, \sigma_{cr})$	(0,27)	(0,30)	(0,37)	(0,40)	(0,43)	(0,45)	(0,45)	(0,45)	(0,45)	(0,45)	(0,45)	
		(γ_{1}, σ_{1})	(0,8,27)	(0,8,30)	(0,3,37)	(0,4,40)	(0,5,43)	(0,6,45)	(0,9,45)	(1,2,45)	(1,6,45)	(2,2,45)	(2,7,45)	(3,3,45)
		(γ_{2}, σ_{2})	(3,3,3)	(3,6,4)	(3,8,4)	(3,9,6)	(4,0,8)	(4,0,11)	(4,0,13)	(4,0,17)	(4,0,21)	(4,0,27)	(4,0,31)	(4,0,38)
	Compressive stiffness [$\times 10^3$ kN/m]		2110	2450	2760	3240	3620	4110	4560	5120	5770	6890	8050	9590
	Nominal long term compressive stress*1 [N/mm ²]		6.9	7.8	10.1	11.5	12.3	13.0	13.0	13.0	13.0	13.0	13.0	13.0
	Nominal long term column load (kN)		1940	2580	3900	5060	6160	7370	8270	9210	10200	12300	14700	17200
Allowable tensile stress ($\gamma = 100\%$) [N/mm ²]		1.0	1.0	1.0	1.0	1.0	1.0	1.0	1.0	1.0	1.0	1.0	1.0	
Shear Properties ($\gamma = 100\%$)	Initial stiffness [$\times 10^3$ kN/m]		4.05	4.73	5.36	6.21	6.93	7.83	8.71	9.79	11.0	13.3	15.5	18.3
	Post yield stiffness ($\gamma = 100\%$) [$\times 10^3$ kN/m]		0.405	0.473	0.536	0.621	0.693	0.783	0.871	0.979	1.10	1.33	1.55	1.83
	Characteristic Strength (kN)		45.2	53.0	61.5	70.6	80.3	90.7	102	113	126	152	181	212
	Equivalent shear stiffness [$\times 10^3$ kN/m]		0.684	0.799	0.905	1.05	1.17	1.32	1.47	1.65	1.86	2.24	2.61	3.09
	Equivalent damping ratio (-)		0.240	0.240	0.240	0.240	0.240	0.240	0.240	0.240	0.240	0.240	0.240	0.240

*1 Nominal long term compressive stress is referred as long term upper limit of compressive stress.

MVBR-0514/MVBR-0520 (X0.6R)

Note: There are 2 certification numbers due to difference of some manufacturing process.
Please refer to "Precautions" in page 6 for the certificate number that used for design document.

Code

Compound name	Rubber code	Shear modulus [N/mm ²]	Equivalent damping ratio
X6R	X0.6R	0.620	0.240

●HL Series (Total Rubber Thickness 16cm)

Characteristics		HL060X6R	HL065X6R	HL070X6R	HL075X6R	HL080X6R	HL085X6R	HL090X6R	HL100X6R	HL110X6R	HL120X6R	HL130X6R	
Physical Dimensions	Outer diameter (mm)	600	650	700	750	800	850	900	1000	1100	1200	1300	
	Inner diameter (mm)	15	15	15	15	20	20	20	25	55	55	55	
	Effective plane area ($\times 10^2$ mm ²)	2826	3317	3847	4416	5023	5671	6359	7849	9480	11286	13249	
	Thickness of one rubber layer (mm)	3.95	4.4	4.9	4.85	5.1	5.25	5.65	6.35	7.2	7.7	8.0	
	Number of rubber layers (-)	41	37	34	34	33	32	30	26	23	22	21	
	Total rubber thickness (mm)	162	163	167	165	168	168	170	165	165	166	169	168
	First shape factor (-)	37.0	36.1	34.9	37.9	38.2	39.5	38.9	38.4	36.3	37.2	38.9	
	Second shape factor (-)	3.70	3.99	4.20	4.55	4.75	5.06	5.31	6.06	6.64	7.08	7.74	
	Diameter of flange (mm)	900	950	1000	1100	1150	1200	1250	1400	1500	1600	1700	
	Thickness of flange (edge/center) (mm)	22/28	22/28	22/28	22/28	24/32	24/32	28/36	28/36	30/38	32/40	32/40	
	Connecting bolt PCD (mm)	775	825	875	950	1000	1050	1100	1250	1350	1450	1550	
	Diameter of connecting bolt hole \times qty (mm)	$\varnothing 33 \times 12$	$\varnothing 33 \times 12$	$\varnothing 33 \times 12$	$\varnothing 33 \times 12$	$\varnothing 33 \times 12$	$\varnothing 33 \times 12$	$\varnothing 33 \times 12$	$\varnothing 39 \times 12$	$\varnothing 39 \times 12$	$\varnothing 39 \times 12$	$\varnothing 39 \times 12$	
	Bolt size (assumption) (-)	M30	M30	M30	M30	M30	M30	M30	M36	M36	M36	M36	
	Thickness of each reinforced steel plate (mm)	3.1	3.1	3.1	3.1	4.4	4.4	4.4	4.4	4.4	4.4	5.8	
	Total height (mm)	342.0	330.4	324.9	323.2	373.1	368.4	369.1	347.1	338.4	341.8	364.0	
	Total weight (tonf)	0.58	0.64	0.70	0.82	1.12	1.23	1.40	1.63	1.88	2.22	2.80	
Total weight (kN)	5.7	6.3	6.9	8.1	11.0	12.1	13.7	15.9	18.4	21.8	27.5		
Compression Properties	Critical stress [N/mm ²]	σ_{cr} when $\gamma = 0$	67	78	86	102	111	125	131	149	164	175	191
	Ultimate compressive stress [N/mm ²]	$(\gamma_{cr}, \sigma_{cr})$	(0,41)	(0,48)	(0,51)	(0,56)	(0,59)	(0,60)	(0,60)	(0,60)	(0,60)	(0,60)	(0,60)
		(γ_{1}, σ_{1})	(1.4,41)	(1.5,48)	(1.7,51)	(2.1,56)	(2.2,59)	(2.6,60)	(2.9,60)	(3.6,60)	(3.8,60)	(3.8,60)	(3.9,60)
		(γ_{2}, σ_{2})	(3.3,7)	(3.4,11)	(3.5,15)	(3.5,23)	(3.6,28)	(3.6,36)	(3.6,41)	(3.7,57)	-	-	-
	Compressive stiffness ($\times 10^3$ kN/m)		2440	2840	3200	3760	4190	4760	5280	6680	7990	9330	11100
	Nominal long term compressive stress [N/mm ²]		10.4	12.0	13.1	15.0	15.0	15.0	15.0	15.0	15.0	15.0	15.0
Nominal long term column load (kN)		2940	3970	5040	6620	7540	8510	9540	11800	14200	16900	19900	
Allowable tensile stress [$\gamma = 100\%$] [N/mm ²]		1.0	1.0	1.0	1.0	1.0	1.0	1.0	1.0	1.0	1.0	1.0	
Shear Properties ($\gamma = 100\%$)	Initial stiffness ($\times 10^3$ kN/m)		6.40	7.48	8.47	9.83	11.0	12.4	13.8	17.4	21.0	24.5	28.9
	Post yield stiffness [$\gamma = 100\%$] ($\times 10^3$ kN/m)		0.640	0.748	0.847	0.983	1.10	1.24	1.38	1.74	2.10	2.45	2.89
	Characteristic Strength (kN)		71.5	83.9	97.3	112	127	143	161	199	240	285	335
	Equivalent shear stiffness ($\times 10^3$ kN/m)		1.08	1.26	1.43	1.66	1.85	2.09	2.33	2.95	3.55	4.13	4.89
	Equivalent damping ratio (-)		0.240	0.240	0.240	0.240	0.240	0.240	0.240	0.240	0.240	0.240	0.240

MVBR-0510/MVBR-0519 (X0.4S)

Note: There are 2 certification numbers due to difference of some manufacturing process.
Please refer to "Precautions" in page 6 for the certificate number that used for design document.

Code

Compound name	Rubber code	Shear modulus (N/mm ²)	Equivalent damping ratio
X4S	X0.4S	0.392	0.240

●HT Series (Total Rubber Thickness 25cm)

Characteristics		HT090X4S	HT095X4S	HT100X4S	HT110X4S	HT120X4S	HT130X4S	HT140X4S	HT150X4S	HT160X4S
Physical Dimensions	Outer diameter (mm)	900	950	1000	1100	1200	1300	1400	1500	1600
	Inner diameter (mm)	20	20	25	55	55	55	65	65	80
	Effective plane area (×10 ² mm ²)	6359	7085	7849	9480	11286	13249	15361	17638	20056
	Thickness of one rubber layer (mm)	6.0	6.4	6.7	7.4	8.0	8.7	9.5	10.0	10.4
	Number of rubber layers (-)	42	39	37	34	31	29	26	25	24
	Total rubber thickness (mm)	252	250	248	252	248	252	247	250	250
	First shape factor (-)	36.7	36.3	36.4	35.3	35.8	35.8	35.1	35.9	36.5
	Second shape factor (-)	3.57	3.81	4.03	4.37	4.84	5.15	5.67	6.00	6.41
	Diameter of flange (mm)	1250	1300	1400	1500	1600	1700	1800	1900	2000
	Thickness of flange ^{×1} (edge/center) (mm)	28/36	28/36	28/36	30/38	32/40	32/40	37/45	42/50	50/110
	Connecting bolt PCD (mm)	1100	1150	1250	1350	1450	1550	1650	1750	1800
	Diameter of connecting bolt hole × qty (mm)	∅ 33 × 12	∅ 33 × 12	∅ 39 × 12	∅ 39 × 12	∅ 39 × 12	∅ 39 × 12	∅ 42 × 12	∅ 42 × 16	∅ 45 × 12
	Bolt size (assumption) (-)	M30	M30	M36	M36	M36	M36	M39	M39	M42
	Thickness of each reinforced steel plate (mm)	4.4	4.4	4.4	4.4	4.4	4.4	5.8	5.8	5.8
	Total height (mm)	504.4	488.8	478.3	472.8	460.0	455.5	482.0	489.2	603.0
	Total weight (tonf)	1.73	1.83	2.00	2.34	2.68	3.01	3.90	4.56	7.22
Total weight (kN)	16.9	18.0	19.6	22.9	26.2	29.5	38.2	44.7	70.8	
Compression Properties	Critical stress (N/mm ²)	σ_{cr} when $\gamma = 0$	33	35	38	43	49	52	58	65
	Ultimate compressive stress (N/mm ²)	$(\gamma_{cr}, \sigma_{cr})$	(0,26)	(0,28)	(0,35)	(0,39)	(0,43)	(0,45)	(0,45)	(0,45)
		(γ_1, σ_1)	(0,8,26)	(0,8,28)	(0,3,35)	(0,4,39)	(0,5,43)	(0,7,45)	(1,2,45)	(1,6,45)
		(γ_2, σ_2)	(3,2,3)	(3,4,4)	(3,6,4)	(3,9,5)	(4,0,9)	(4,0,12)	(4,0,17)	(4,0,20)
	Compressive stiffness (×10 ³ kN/m)		3040	3420	3810	4520	5470	6310	7450	8480
	Nominal long term compressive stress ^{×2} (N/mm ²)		6.4	7.2	9.5	10.8	12.6	13.0	13.0	13.0
	Nominal long term column load (kN)		4090	5090	7450	10200	14200	17200	20000	22900
Allowable tensile stress ($\gamma = 100\%$) (N/mm ²)		1.0	1.0	1.0	1.0	1.0	1.0	1.0	1.0	
Shear Properties ($\gamma = 100\%$)	Initial stiffness (×10 ³ kN/m)		5.86	6.59	7.35	8.74	10.6	12.2	14.4	18.6
	Post yield stiffness (×10 ³ kN/m)		0.586	0.659	0.735	0.874	1.06	1.22	1.44	1.86
	Characteristic Strength (kN)		102	113	126	152	181	212	246	321
	Equivalent shear stiffness (×10 ³ kN/m)		0.989	1.11	1.24	1.48	1.78	2.06	2.44	3.15
	Equivalent damping ratio (-)		0.240	0.240	0.240	0.240	0.240	0.240	0.240	0.240

×1 Special thickness for flange is available. Please refer to the table on the next page (upper top table) for more details.

×2 Nominal long term compressive stress is referred as long term upper limit of compressive stress.

Specification of flange (edge thickness / center thickness)

Outer diameter of rubber bearing (Ø) ^{*1}	(900)	(950)	1000	1100	1200	1300
Standard thickness	28/36	28/36	28/36	30/38	32/40	32/40
Special thickness (option)	(37/45)	(37/45)	42/50	42/50	42/50	42/50

×1 For adoption of special thickness in regard to those sizes that stated in the (), delivery time will be longer due to mold preparation.
 ×2 For Ø1400 and above, assembled type flange will be used.
 ×3 Compared to the standard specification, total height & weight of product for special thickness will be changed.

MVBR-0514/MVBR-0520 (X0.6R)

Note: There are 2 certification numbers due to difference of some manufacturing process.
 Please refer to "Precautions" in page 6 for the certificate number that used for design document.

Code

Compound name	Rubber code	Shear modulus [N/mm ²]	Equivalent damping ratio
X6R	X0.6R	0.620	0.240

●HT Series (Total Rubber Thickness 25cm)

Characteristics		HT090X6R	HT095X6R	HT100X6R	HT110X6R	HT120X6R	HT130X6R	HT140X6R	HT150X6R	HT160X6R	
Physical Dimensions	Outer diameter (mm)	900	950	1000	1100	1200	1300	1400	1500	1600	
	Inner diameter (mm)	20	20	25	55	55	55	65	65	80	
	Effective plane area (×10 ² mm ²)	6359	7085	7849	9480	11286	13249	15361	17638	20056	
	Thickness of one rubber layer (mm)	6.0	6.4	6.7	7.4	8.0	8.7	9.5	10.0	10.4	
	Number of rubber layers (-)	42	39	37	34	31	29	26	25	24	
	Total rubber thickness (mm)	252	250	248	252	248	252	247	250	250	
	First shape factor (-)	36.7	36.3	36.4	35.3	35.8	35.8	35.1	35.9	36.5	
	Second shape factor (-)	3.57	3.81	4.03	4.37	4.84	5.15	5.67	6.00	6.41	
	Diameter of flange (mm)	1250	1300	1400	1500	1600	1700	1800	1900	2000	
	Thickness of flange ^{*1} (edge/center) (mm)	28/36	28/36	28/36	30/38	32/40	32/40	37/45	42/50	50/110	
	Connecting bolt PCD (mm)	1100	1150	1250	1350	1450	1550	1650	1750	1800	
	Diameter of connecting bolt hole × qty	Ø 33 × 12	Ø 33 × 12	Ø 39 × 12	Ø 39 × 12	Ø 39 × 12	Ø 39 × 12	Ø 42 × 12	Ø 42 × 16	Ø 45 × 12	
	Bolt size (assumption) (-)	M30	M30	M36	M36	M36	M36	M39	M39	M42	
	Thickness of each reinforced steel plate (mm)	4.4	4.4	4.4	4.4	4.4	4.4	5.8	5.8	5.8	
	Total height (mm)	504.4	488.8	478.3	472.8	460.0	455.5	482.0	489.2	603.0	
	Total weight (tonf)	1.73	1.83	2.00	2.34	2.68	3.01	3.90	4.56	7.22	
Total weight (kN)	16.9	18.0	19.6	22.9	26.2	29.5	38.2	44.7	70.8		
Compression Properties	Critical stress [N/mm ²]	σ_{cr} when $\gamma = 0$	62	71	80	94	115	127	140	158	
	Ultimate compressive stress [N/mm ²]	$(\gamma_{cr}, \sigma_{cr})$	(0,38)	(0,43)	(0,48)	(0,53)	(0,60)	(0,60)	(0,60)	(0,60)	(0,60)
		(γ_1, σ_1)	(1.4,38)	(1.5,43)	(1.6,48)	(1.9,53)	(2.3,60)	(2.7,60)	(3.2,60)	(3.6,60)	(3.8,60)
		(γ_2, σ_2)	(3.2,6)	(3.4,8)	(3.4,12)	(3.5,19)	(3.6,30)	(3.6,38)	(3.7,49)	(3.7,56)	-
	Compressive stiffness (×10 ³ kN/m)		3530	3960	4420	5240	6340	7310	8640	9830	11200
	Nominal long term compressive stress [N/mm ²]		9.7	11.0	12.2	14.0	15.0	15.0	15.0	15.0	15.0
Nominal long term column load (kN)		6170	7790	9580	13300	16900	19900	23000	26500	30100	
Allowable tensile stress ($\gamma = 100\%$) [N/mm ²]		1.0	1.0	1.0	1.0	1.0	1.0	1.0	1.0	1.0	
Shear Properties ($\gamma = 100\%$)	Initial stiffness (×10 ³ kN/m)		9.26	10.4	11.6	13.8	16.7	19.3	22.8	29.5	
	Post yield stiffness ($\gamma = 100\%$) (×10 ³ kN/m)		0.926	1.04	1.16	1.38	1.67	1.93	2.28	2.95	
	Characteristic Strength (kN)		161	179	199	240	285	335	389	446	507
	Equivalent shear stiffness (×10 ³ kN/m)		1.56	1.76	1.96	2.34	2.82	3.26	3.86	4.37	4.98
	Equivalent damping ratio (-)		0.240	0.240	0.240	0.240	0.240	0.240	0.240	0.240	0.240

×1 Special thickness for flange is available. Please refer to the table above for more details.

Specification of flange (edge thickness / center thickness)

Outer diameter of rubber bearing (Ø) ^{*1}	(600)	(650)	700	750	800	850	900	950	1000	1100	1200	1300
Standard thickness	22/28	22/28	22/28	22/28	24/32	24/32	28/36	28/36	28/36	30/38	32/40	32/40
Special thickness (option)	[26/32]	[26/32]	26/32	[30/36]	32/40	32/40	37/45	37/45	42/50	42/50	42/50	42/50

×1 For adoption of special thickness in regard to those sizes that stated in the (), delivery time will be longer due to mold preparation.
 ×2 For Ø1400 and above, assembled type flange will be used.
 ×3 Compared to the standard specification, total height & weight of product for special thickness will be changed.

MVBR-0510/MVBR-0519 (X0.4S)

Note: There are 2 certification numbers due to difference of some manufacturing process.
 Please refer to "Precautions" in page 6 for the certificate number that used for design document.

●HS Series (S₂ = 5)

Code

Compound name	Rubber code	Shear modulus (N/mm ²)	Equivalent damping ratio
X4S	X0.4S	0.392	0.240

Characteristics		HS070X4S	HS075X4S	HS080X4S	HS085X4S	HS090X4S	HS095X4S	HS100X4S	HS110X4S	HS120X4S	HS130X4S	HS140X4S	HU150X4S	
Physical Dimensions	Outer diameter (mm)	700	750	800	850	900	950	1000	1100	1200	1300	1400	1500	
	Inner diameter (mm)	15	15	20	20	20	20	25	55	55	55	65	65	
	Effective plane area (×10 ² mm ²)	3847	4416	5023	5671	6359	7085	7849	9480	11286	13249	15361	17638	
	Thickness of one rubber layer (mm)	4.7	5	5.4	5.7	6.0	6.4	6.7	7.4	8.0	8.7	9.3	8.5	
	Number of rubber layers (-)	30	30	30	30	30	30	30	30	30	30	30	35	
	Total rubber thickness (mm)	141	150	162	171	180	192	201	222	240	261	279	298	
	First shape factor (-)	36.4	36.8	36.1	36.4	36.7	36.3	36.4	35.3	35.8	35.8	35.9	42.2	
	Second shape factor (-)	4.96	5.00	4.94	4.97	5.00	4.95	4.98	4.95	5.00	4.98	5.02	5.04	
	Diameter of flange (mm)	1000	1100	1150	1200	1250	1300	1400	1500	1600	1700	1800	1900	
	Thickness of flange ^{*1} (edge/center) (mm)	22/28	22/28	24/32	24/32	28/36	28/36	28/36	30/38	32/40	32/40	37/45	50/100	
	Connecting bolt PCD (mm)	875	950	1000	1050	1100	1150	1250	1350	1450	1550	1650	1750	
	Diameter of connecting bolt hole × qty (mm)	Ø33 × 12	Ø33 × 12	Ø33 × 12	Ø33 × 12	Ø33 × 12	Ø33 × 12	Ø39 × 12	Ø39 × 12	Ø39 × 12	Ø39 × 12	Ø39 × 12	Ø42 × 12	Ø42 × 16
	Bolt size (assumption) (-)	M30	M30	M30	M30	M30	M30	M36	M36	M36	M36	M39	M39	
	Thickness of each reinforced steel plate (mm)	3.1	3.1	4.4	4.4	4.4	4.4	4.4	4.4	4.4	4.4	5.8	5.8	
	Total height (mm)	286.9	295.9	353.6	362.6	379.6	391.6	400.6	425.6	447.6	468.6	537.2	694.7	
Total weight (tonf)	0.65	0.77	1.07	1.19	1.41	1.56	1.77	2.17	2.63	3.07	4.24	7.04		
Total weight (kN)	6.4	7.5	10.5	11.7	13.8	15.3	17.3	21.3	25.8	30.1	41.6	69.1		
Compression Properties	Critical stress (N/mm ²)	σ_{cr} when $\gamma = 0$	50	51	50	50	51	50	51	50	51	51	51	
	Ultimate compressive stress (N/mm ²)	$(\gamma_{cr}, \sigma_{cr})$	(0,45)	(0,45)	(0,44)	(0,45)	(0,45)	(0,44)	(0,45)	(0,45)	(0,45)	(0,45)	(0,45)	(0,45)
		(γ_1, σ_1)	(0.5,45)	(0.6,45)	(0.6,44)	(0.5,45)	(0.6,45)	(0.6,44)	(0.5,45)	(0.5,45)	(0.6,45)	(0.6,45)	(0.6,45)	(0.6,45)
		(γ_2, σ_2)	(4.0,10)	(4.0,10)	(4.0,10)	(4.0,10)	(4.0,10)	(4.0,10)	(4.0,10)	(4.0,10)	(4.0,10)	(4.0,10)	(4.0,10)	(4.0,11)
	Compressive stiffness (×10 ³ kN/m)		3290	3550	3730	4000	4260	4440	4700	5120	5650	6100	6620	7280
	Nominal long term compressive stress ^{*2} (N/mm ²)		13.0	13.0	13.0	13.0	13.0	13.0	13.0	13.0	13.0	13.0	13.0	13.0
	Nominal long term column load (kN)		5000	5740	6530	7370	8270	9210	10200	12300	14700	17200	20000	22900
Allowable tensile stress ($\gamma = 100\%$) (N/mm ²)		1.0	1.0	1.0	1.0	1.0	1.0	1.0	1.0	1.0	1.0	1.0	1.0	
Shear Properties ($\gamma = 100\%$)	Initial stiffness (×10 ³ kN/m)		6.33	6.83	7.20	7.70	8.20	8.56	9.06	9.91	10.9	11.8	12.8	13.8
	Post yield stiffness ($\gamma = 100\%$) (×10 ³ kN/m)		0.633	0.683	0.720	0.770	0.820	0.856	0.906	0.991	1.091	1.178	1.278	1.376
	Characteristic Strength (kN)		61.5	70.6	80.3	90.7	102	113	126	152	181	212	246	282
	Equivalent shear stiffness (×10 ³ kN/m)		1.07	1.15	1.22	1.30	1.38	1.45	1.53	1.67	1.84	1.99	2.16	2.32
	Equivalent damping ratio (-)		0.240	0.240	0.240	0.240	0.240	0.240	0.240	0.240	0.240	0.240	0.240	0.240

×1 Special thickness for flange is available. Please refer to the table above for more details.

×2 Nominal long term compressive stress is referred as long term upper limit of compressive stress.

Certification Number MVBR-0514 (X0.6R)

Code

Compound name	Rubber code	Shear modulus [N/mm ²]	Equivalent damping ratio
X6R	X0.6R	0.620	0.240

●HD Series (Total Rubber Thickness 32cm)

Characteristics		HD160X6R	HD170X6R	HD180X6R	
Physical Dimensions	Outer diameter (mm)	1600	1700	1800	
	Inner diameter (mm)	80	85	5 – Ø55	
	Effective plane area (×10 ² mm ²)	20056	22641	25328	
	Thickness of one rubber layer (mm)	10.4	10.4	11.1	
	Number of rubber layers (-)	31	31	29	
	Total rubber thickness (mm)	322	322	322	
	First shape factor (-)	36.5	38.8	35.0	
	Second shape factor (-)	4.96	5.27	5.59	
	Diameter of flange (mm)	2000	□ 1980	□ 2080	
	Thickness of flange (edge/center) (mm)	50/100	50/100	50/100	
	Connecting bolt PCD (mm)	1800	-	-	
	Diameter of connecting bolt hole × qty (mm)	Ø 45 × 12	Ø 45 × 24	Ø 45 × 24	
	Bolt size (assumption) (-)	M42	M42	M42	
	Thickness of each reinforced steel plate (mm)	5.8	5.8	5.8	
	Total height (mm)	696.4	696.4	684.3	
	Total weight (tonf)	7.69	9.02	9.79	
	Total weight (kN)	75.4	88.4	96.0	
Compression Properties	Critical stress [N/mm ²]	121	130	138	
	Ultimate compressive stress [N/mm ²]	σ_{cr} when $\gamma = 0$	(0,60)	(0,60)	(0,60)
		(γ_1, σ_1)	(2.5,60)	(2.8,60)	(3.2,60)
		(γ_2, σ_2)	(3.6,34)	(3.6,41)	(3.7,41)
	Compressive stiffness (×10 ³ kN/m)	8690	9890	10900	
	Nominal long term compressive stress [N/mm ²]	15.0	15.0	15.0	
	Nominal long term column load (kN)	30100	34000	38000	
Allowable tensile stress ($\gamma = 100\%$) [N/mm ²]	1.0	1.0	1.0		
Shear Properties ($\gamma = 100\%$)	Initial stiffness (×10 ³ kN/m)	22.8	25.8	28.9	
	Post yield stiffness ($\gamma = 100\%$) (×10 ³ kN/m)	2.28	2.58	2.89	
	Characteristic Strength (kN)	507	573	641	
	Equivalent shear stiffness (×10 ³ kN/m)	3.86	4.35	4.88	
	Equivalent damping ratio (-)	0.240	0.240	0.240	

Lead Rubber Bearing (LRB)

●LH Series (Total Rubber Thickness 20cm)

P.27

Outer diameter of rubber bearing, Do(mm) Lead plug diameter, Dp(mm)	600	650	700	750	800	850	900	950	1000	1100	1200	1300	1400	1500
370														M
360														L
350														K
340													L	J
330													K	I
320												L	J	H
310												K	I	G
300											L	J	H	A
290											K	I	G	B
280											J	H	A	C
270										K	I	G	B	D
260										J	H	A	C	E
250									K	I	G	B	D	F
240								K	J	H	A	C	E	S
230							K	J	I	G	B	D	F	T
220						K	J	I	H	A	C	E	S	
210					J	I	H	G	B	D	F	T		
200				J	I	H	G	A	C	E	S			
190			J	I	H	G	A	B	D	F				
180			J	I	H	G	A	B	C	E	S			
170		J	I	H	G	A	B	C	D	F				
160	J	I	H	G	A	B	C	D	E					
150	I	H	G	A	B	C	D	E	F					
140	H	G	A	B	C	D	E	F						
130	G	A	B	C	D	E	F							
120	A	B	C	D	E	F								
110	B	C	D	E										
100	C	D	E											
90	D	E												
80	E													

●LL Series (Total Rubber Thickness 16cm)

P.36

Outer diameter of rubber bearing, Do(mm) Lead plug diameter, Dp(mm)	600	650	700	750	800	850	900	950	1000	1100	1200	1300
320												L
310												K
300											L	J
290											K	I
280											J	H
270										K	I	G
260										J	H	A
250									K	I	G	B
240								K	J	H	A	C
230							K	J	I	G	B	D
220						K	J	I	H	A	C	E
210					J	I	H	G	B	D	F	
200				J	I	H	G	A	C	E	S	
190			J	I	H	G	A	B	D	F		
180			J	I	H	G	A	B	C	E	S	
170		J	I	H	G	A	B	C	D	F		
160	J	I	H	G	A	B	C	D	E			
150	I	H	G	A	B	C	D	E	F			
140	H	G	A	B	C	D	E	F				
130	G	A	B	C	D	E	F					
120	A	B	C	D	E	F						
110	B	C	D	E								
100	C	D	E									
90	D	E										
80	E											

●LT Series (Total Rubber Thickness 25cm)

P.43

Outer diameter of rubber bearing, Do(mm)	900	950	1000	1100	1200	1300	1400	1500	1600
Lead plug diameter, Dp(mm)									
390									M
380									L
370								M	K
360								L	J
350								K	I
340							L	J	H
330							K	I	G
320						L	J	H	A
310						K	I	G	B
300					L	J	H	A	C
290					K	I	G	B	D
280					J	H	A	C	E
270				K	I	G	B	D	F
260				J	H	A	C	E	S
250			K	I	G	B	D	F	T
240		K	J	H	A	C	E	S	
230	K	J	I	G	B	D	F	T	
220	J	I	H	A	C	E	S		
210	I	H	G	B	D	F	T		
200	H	G	A	C	E	S			
190	G	A	B	D	F				
180	A	B	C	E	S				
170	B	C	D	F					
160	C	D	E						
150	D	E	F						
140	E	F							
130	F								

●LD Series (Total Rubber Thickness 32cm) P.50

Outer diameter of rubber bearing, Do(mm)	1600	1700	1800
Lead plug diameter, Dp(mm)			
215 × 4			M
210 × 4			L
205 × 4			K
200 × 4		L	J
390	M	K	I
380	L	J	H
370	K	I	G
360	J	H	A
350	I	G	B
340	H	A	C
330	G	B	D
320	A	C	E
310	B	D	F
300	C	E	S
290	D	F	
280	E	S	
270	F		
260	S		
250	T		

●LS Series (S₂=5)

P.53

Outer diameter of rubber bearing, Do(mm)	600	650	700	750	800	850	900	950	1000	1100	1200	1300	1400	1500
Lead plug diameter, Dp(mm)														
370														M
360														L
350														K
340													L	J
330													K	I
320												L	J	H
310												K	I	G
300											L	J	H	A
290											K	I	G	B
280											J	H	A	C
270										K	I	G	B	D
260										J	H	A	C	E
250														
240									K	J	I	G	B	D
230							K	J	I	H	A	C	E	S
220								K	J	I	H	A	C	E
210							J	I	H	G	B	D	F	T
200					J	I	H	G	A	C	E	S		
190				J	I	H	G	A	B	D	F			
180			J	I	H	G	A	B	C	E	S			
170		J	I	H	G	A	B	C	D	F				
160	J	I	H	G	A	B	C	D	E					
150	I	H	G	A	B	C	D	E	F					
140	H	G	A	B	C	D	E	F						
130	G	A	B	C	D	E	F							
120	A	B	C	D	E	F								
110	B	C	D	E										
100	C	D	E											
90	D	E												
80	E													

Description of the product designation

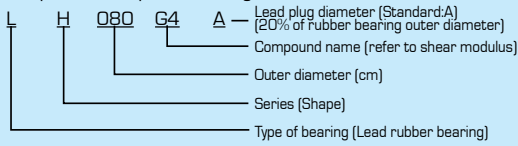

Type of lead plug

(mm)

Type	T	S	F	E	D	C	B	A	G	H	I	J	K	L	M
Lead plug diameter	A-70	A-60	A-50	A-40	A-30	A-20	A-10	Dø/5	A+10	A+20	A+30	A+40	A+50	A+60	A+70

* assortment of lead plug diameter is depending on the size of rubber bearing.

Certification number MVBR-0517

Code

Compound name	Rubber code	Shear modulus [N/mm ²]
G4	G0.40	0.385

● LH Series (Total Rubber Thickness 20cm)

Characteristics		LH060G4										LH065G4									
		E	D	C	B	A	G	H	I	J	E	D	C	B	A	G	H	I	J		
Physical Dimensions	Outer diameter (mm)	600										650									
	Lead plug diameter (mm)	80	90	100	110	120	130	140	150	160	90	100	110	120	130	140	150	160	170		
	Effective plane area (×10 ² mm ²)	2777	2764	2749	2732	2714	2695	2673	2651	2626	3255	3240	3223	3205	3186	3164	3142	3117	3091		
	Thickness of one rubber layer (mm)	4.0										4.4									
	Number of rubber layers	50										45									
	Total rubber thickness (mm)	200										198									
	First shape factor	37.5										36.9									
	Second shape factor	3.00										3.28									
	Diameter of flange (mm)	900										950									
	Thickness of flange ^{*1} (edge/center) (mm)	22/28										22/28									
	Connecting bolt PCD (mm)	775										825									
	Diameter of connecting bolt hole × qty	∅ 33 × 12										∅ 33 × 12									
	Bolt size (assumption)	M30										M30									
	Thickness of each reinforced steel plate (mm)	3.1										3.1									
Total height (mm)	407.9										390.4										
Total weight (tonf)	0.67	0.68	0.68	0.69	0.69	0.70	0.70	0.71	0.71	0.74	0.74	0.74	0.75	0.75	0.76	0.77	0.77	0.78			
Total weight (kN)	6.6	6.6	6.7	6.7	6.8	6.8	6.9	6.9	7.0	7.2	7.2	7.3	7.3	7.4	7.4	7.5	7.6	7.6			
Compression Properties	Critical stress (N/mm ²)	24										30									
	Ultimate compressive stress (N/mm ²)	[γ ₀ , σ ₀]										[0.00,30]									
		[γ ₁ , σ ₁]										[0.00,30]									
		[γ ₂ , σ ₂]										[3.28,3]									
	Compressive stiffness (×10 ³ kN/m)	1670										1970									
	Nominal long term compressive stress (N/mm ²)	6.0										7.3									
	Nominal long term column load (kN)	1670	1660	1650	1640	1630	1620	1600	1590	1580	2370	2360	2350	2330	2320	2300	2290	2270	2250		
Allowable tensile stress (γ = 100%) (N/mm ²)	1.0										1.0										
Shear Properties (γ = 100%)	Initial stiffness (×10 ³ kN/m)	7.14	7.16	7.18	7.20	7.22	7.25	7.27	7.30	7.33	8.47	8.49	8.51	8.53	8.56	8.59	8.62	8.65	8.68		
	Post yield stiffness (γ = 100%) (×10 ³ kN/m)	0.549	0.551	0.552	0.554	0.555	0.557	0.560	0.562	0.564	0.652	0.653	0.655	0.657	0.658	0.661	0.663	0.665	0.668		
	Characteristic Strength (kN)	40.0	50.7	62.6	75.7	90.1	106	123	141	160	50.7	62.6	75.7	90.1	106	123	141	160	181		
	Equivalent shear stiffness (×10 ³ kN/m)	0.749	0.804	0.865	0.932	1.01	1.09	1.17	1.27	1.37	0.908	0.969	1.04	1.11	1.19	1.28	1.37	1.47	1.58		
	Equivalent damping ratio	0.165	0.193	0.219	0.244	0.266	0.285	0.302	0.317	0.329	0.174	0.199	0.223	0.246	0.266	0.284	0.300	0.314	0.326		

*1 Special thickness for flange is available. Please refer to the table on page 29 for more details.

Certification number MVBR-0517

●LH Series (Total Rubber Thickness 20cm)

Characteristics		LH070G4										LH075G4										
		E	D	C	B	A	G	H	I	J	E	D	C	B	A	G	H	I	J			
Physical Dimensions	Outer diameter (mm)	700										750										
	Lead plug diameter (mm)	100	110	120	130	140	150	160	170	180	110	120	130	140	150	160	170	180	190			
	Effective plane area ($\times 10^2$ mm ²)	3770	3753	3735	3716	3695	3672	3647	3621	3594	4323	4305	4285	4264	4241	4217	4191	4163	4134			
	Thickness of one rubber layer (mm)	4.7										5.0										
	Number of rubber layers (-)	43										40										
	Total rubber thickness (mm)	202										200										
	First shape factor (-)	372										375										
	Second shape factor (-)	3.46										3.75										
	Diameter of flange (mm)	1000										1100										
	Thickness of flange* ¹ (edge/center) (mm)	22/28										22/28										
	Connecting bolt PCD (mm)	875										950										
	Diameter of connecting bolt hole \times qty (mm)	$\varnothing 33 \times 12$										$\varnothing 33 \times 12$										
	Bolt size (assumption) (-)	M30										M30										
	Thickness of each reinforced steel plate (mm)	3.1										3.1										
	Total height (mm)	388.3										376.9										
Total weight (tonf)	0.82	0.83	0.83	0.84	0.85	0.85	0.86	0.87	0.87	0.93	0.93	0.94	0.95	0.95	0.96	0.97	0.97	0.98				
Total weight (kN)	8.1	8.1	8.2	8.2	8.3	8.4	8.4	8.5	8.6	9.1	9.2	9.2	9.3	9.3	9.4	9.5	9.5	9.6				
Compression Properties	Critical stress (N/mm ²) σ_{cr} when $\gamma = 0$	35										42										
	Ultimate compressive stress (N/mm ²)	(γ_0, σ_0)	(0.00,35)										(0.00,42)									
		(γ_1, σ_1)	(0.00,35)										(0.00,42)									
		(γ_2, σ_2)	(3.46,3)										(3.75,4)									
	Compressive stiffness ($\times 10^3$ kN/m)	2250										2610										
	Nominal long term compressive stress (N/mm ²)	8.1										9.4										
	Nominal long term column load (kN)	3050	3040	3020	3010	2990	2970	2950	2930	2910	4060	4040	4020	4000	3980	3960	3930	3910	3880			
Allowable tensile stress ($\gamma = 100\%$) (N/mm ²)	1.0										1.0											
Shear Properties ($\gamma = 100\%$)	Initial stiffness ($\times 10^3$ kN/m)	9.63	9.65	9.67	9.70	9.73	9.76	9.79	9.82	9.85	11.2	11.2	11.2	11.3	11.3	11.3	11.3	11.4	11.4			
	Post yield stiffness ($\gamma = 100\%$) ($\times 10^3$ kN/m)	0.741	0.742	0.744	0.746	0.748	0.750	0.753	0.755	0.758	0.860	0.862	0.864	0.866	0.868	0.870	0.873	0.876	0.879			
	Characteristic Strength (kN)	62.6	75.7	90.1	106	123	141	160	181	203	75.7	90.1	106	123	141	160	181	203	226			
	Equivalent shear stiffness ($\times 10^3$ kN/m)	1.05	1.12	1.19	1.27	1.36	1.45	1.55	1.65	1.76	1.24	1.31	1.39	1.48	1.57	1.67	1.78	1.89	2.01			
	Equivalent damping ratio (-)	0.181	0.205	0.227	0.247	0.266	0.283	0.298	0.311	0.323	0.187	0.209	0.229	0.248	0.266	0.282	0.296	0.309	0.320			

* : Special thickness for flange is available. Please refer to the table on the next page (upper top table) for more details.

Specification of flange (edge thickness / center thickness)

Outer diameter of rubber bearing (Ø) ^{*1}	(600)	(650)	700	750	800	850	900	950	1000	1100	1200	1300
Standard thickness	22/28	22/28	22/28	22/28	24/32	24/32	28/36	28/36	28/36	30/38	32/40	32/40
Special thickness (option)	(26/32)	(26/32)	26/32	30/36	32/40	32/40	37/45	37/45	42/50	42/50	42/50	42/50

*1 For adoption of special thickness in regard to those sizes that stated in the (), delivery time will be longer due to mold preparation.

*2 For Ø1400 and above, assembled type flange will be used.

*3 Compared to the standard specification, total height & weight of product for special thickness will be changed.

Certification number MVBR-0517

●LH Series (Total Rubber Thickness 20cm)

Characteristics		LH080G4										LH085G4											
		E	D	C	B	A	G	H	I	J	F	E	D	C	B	A	G	H	I	J	K		
Physical Dimensions	Outer diameter (mm)	800										850											
	Lead plug diameter (mm)	120	130	140	150	160	170	180	190	200	120	130	140	150	160	170	180	190	200	210	220		
	Effective plane area (×10 ² mm ²)	4913	4894	4873	4850	4825	4800	4772	4743	4712	5561	5542	5521	5498	5473	5448	5420	5391	5360	5328	5294		
	Thickness of one rubber layer (mm)	5.4										5.7											
	Number of rubber layers (-)	37										35											
	Total rubber thickness (mm)	200										200											
	First shape factor (-)	37.0										37.3											
	Second shape factor (-)	4.00										4.26											
	Diameter of flange (mm)	1150										1200											
	Thickness of flange ^{*1} (edge/center) (mm)	24/32										24/32											
	Connecting bolt PCD (mm)	1000										1050											
	Diameter of connecting bolt hole × qty (mm)	Ø 33 × 12										Ø 33 × 12											
	Bolt size (assumption) (-)	M30										M30											
	Thickness of each reinforced steel plate (mm)	4.4										4.4											
	Total height (mm)	422.2										413.1											
Total weight (tonf)	1.25	1.25	1.26	1.26	1.27	1.28	1.29	1.29	1.30	1.34	1.35	1.36	1.36	1.37	1.38	1.38	1.39	1.40	1.41	1.42			
Total weight (kN)	12.2	12.3	12.3	12.4	12.5	12.5	12.6	12.7	12.8	13.2	13.2	13.3	13.4	13.4	13.5	13.6	13.7	13.7	13.8	13.9			
Compression Properties	Critical stress (N/mm ²)	σ_{cr} when $\gamma = 0$		49										56									
	Ultimate compressive stress (N/mm ²)	(γ'_0, σ_0)		(0.00,49)										(0.00,56)									
		(γ'_1, σ_1)		(0.00,49)										(0.00,56)									
		(γ'_2, σ_2)		(4.00,5)										(4.00,9)									
	Compressive stiffness (×10 ³ kN/m)			2960										3360									
	Nominal long term compressive stress (N/mm ²)			10.5										11.7									
	Nominal long term column load (kN)	5180	5160	5130	5110	5080	5060	5030	5000	4960	6500	6480	6460	6430	6400	6370	6340	6300	6270	6230	6190		
Allowable tensile stress ($\gamma = 100\%$) (N/mm ²)			1.0										1.0										
Shear Properties ($\gamma = 100\%$)	Initial stiffness (×10 ³ kN/m)	12.7	12.8	12.8	12.8	12.9	12.9	12.9	13.0	13.0	14.4	14.4	14.4	14.5	14.5	14.5	14.6	14.6	14.6	14.7	14.7		
	Post yield stiffness ($\gamma = 100\%$) (×10 ³ kN/m)	0.980	0.982	0.984	0.986	0.989	0.991	0.994	0.997	1.00	1.11	1.11	1.11	1.11	1.12	1.12	1.12	1.12	1.13	1.13	1.13		
	Characteristic Strength (kN)	90.1	106	123	141	160	181	203	226	250	90.1	106	123	141	160	181	203	226	250	276	303		
	Equivalent shear stiffness (×10 ³ kN/m)	1.43	1.51	1.60	1.69	1.79	1.90	2.01	2.13	2.25	1.56	1.64	1.73	1.82	1.92	2.02	2.14	2.26	2.38	2.51	2.65		
	Equivalent damping ratio (-)	0.193	0.213	0.232	0.250	0.266	0.281	0.294	0.306	0.317	0.178	0.198	0.216	0.234	0.251	0.266	0.280	0.293	0.304	0.315	0.324		

* : Special thickness for flange is available. Please refer to the table above for more details.

Certification number MVBR-0517

●LH Series (Total Rubber Thickness 20cm)

Characteristics		LH090G4											LH095G4												
		F	E	D	C	B	A	G	H	I	J	K	F	E	D	C	B	A	G	H	I	J	K		
Physical Dimensions	Outer diameter (mm)	900											950												
	Lead plug diameter (mm)	130	140	150	160	170	180	190	200	210	220	230	140	150	160	170	180	190	200	210	220	230	240		
	Effective plane area ($\times 10^2$ mm ²)	6229	6208	6185	6161	6135	6107	6078	6048	6015	5982	5946	6934	6912	6887	6861	6834	6805	6774	6742	6708	6673	6636		
	Thickness of one rubber layer (mm)	6.0											6.4												
	Number of rubber layers (-)	33											31												
	Total rubber thickness (mm)	198											198												
	First shape factor (-)	375											371												
	Second shape factor (-)	4.55											4.79												
	Diameter of flange (mm)	1250											1300												
	Thickness of flange* ¹ (edge/center) (mm)	28/36											28/36												
	Connecting bolt PCD (mm)	1100											1150												
	Diameter of connecting bolt hole \times qty (mm)	$\varnothing 33 \times 12$											$\varnothing 33 \times 12$												
	Bolt size (assumption) (-)	M30											M30												
	Thickness of each reinforced steel plate (mm)	4.4											4.4												
	Total height (mm)	410.8											402.4												
Total weight (tonf)	1.52	1.53	1.54	1.54	1.55	1.56	1.57	1.57	1.58	1.59	1.60	1.64	1.64	1.65	1.66	1.66	1.67	1.68	1.69	1.70	1.71	1.72			
Total weight (kN)	14.9	15.0	15.1	15.1	15.2	15.3	15.4	15.4	15.5	15.6	15.7	16.0	16.1	16.2	16.2	16.3	16.4	16.5	16.6	16.6	16.7	16.8			
Compression Properties	Critical stress (N/mm ²)	σ_{cr} when $\gamma = 0$		66											74										
	Ultimate compressive stress (N/mm ²)	(γ'_0, σ_0)		(0.00,60)											(0.00,60)										
		(γ'_1, σ_1)		(0.43,60)											(0.98,60)										
		(γ'_2, σ_2)		(4.00,14)											(4.00,18)										
	Compressive stiffness ($\times 10^3$ kN/m)	3800											4210												
	Nominal long term compressive stress (N/mm ²)	13.0											13.0												
	Nominal long term column load (kN)	8080	8060	8030	8000	7960	7930	7890	7850	7810	7760	7720	9010	8980	8950	8920	8880	8850	8810	8760	8720	8670	8630		
Allowable tensile stress ($\gamma = 100\%$) (N/mm ²)	1.0											1.0													
Shear Properties ($\gamma = 100\%$)	Initial stiffness ($\times 10^3$ kN/m)	16.3	16.3	16.3	16.3	16.4	16.4	16.4	16.5	16.5	16.6	16.6	18.1	18.1	18.1	18.2	18.2	18.2	18.3	18.3	18.4	18.4	18.5		
	Post yield stiffness ($\gamma = 100\%$) ($\times 10^3$ kN/m)	1.25	1.25	1.25	1.26	1.26	1.26	1.27	1.27	1.27	1.28	1.28	1.39	1.39	1.40	1.40	1.40	1.40	1.41	1.41	1.41	1.42	1.42		
	Characteristic Strength (kN)	106	123	141	160	181	203	226	250	276	303	331	123	141	160	181	203	226	250	276	303	331	360		
	Equivalent shear stiffness ($\times 10^3$ kN/m)	1.78	1.87	1.97	2.07	2.17	2.29	2.41	2.53	2.67	2.80	2.95	2.01	2.10	2.20	2.31	2.42	2.54	2.67	2.80	2.94	3.09	3.24		
	Equivalent damping ratio (-)	0.184	0.202	0.219	0.236	0.251	0.266	0.279	0.291	0.302	0.312	0.321	0.189	0.206	0.222	0.238	0.252	0.266	0.278	0.290	0.301	0.310	0.319		

* : Special thickness for flange is available. Please refer to the table on the next page [upper top table] for more details.

Specification of flange (edge thickness / center thickness)

Outer diameter of rubber bearing (Ø) ^{*1}	(600)	(650)	700	750	800	850	900	950	1000	1100	1200	1300
Standard thickness	22/28	22/28	22/28	22/28	24/32	24/32	28/36	28/36	28/36	30/38	32/40	32/40
Special thickness (option)	(26/32)	(26/32)	26/32	30/36	32/40	32/40	37/45	37/45	42/50	42/50	42/50	42/50

*1 For adoption of special thickness in regard to those sizes that stated in the (), delivery time will be longer due to mold preparation.

*2 For Ø1400 and above, assembled type flange will be used.

*3 Compared to the standard specification, total height & weight of product for special thickness will be changed.

Certification number MVBR-0517

●LH Series (Total Rubber Thickness 20cm)

Characteristics		LH100G4											LH110G4											
		F	E	D	C	B	A	G	H	I	J	K	F	E	D	C	B	A	G	H	I	J	K	
Physical Dimensions	Outer diameter (mm)	1000											1100											
	Lead plug diameter (mm)	150	160	170	180	190	200	210	220	230	240	250	170	180	190	200	210	220	230	240	250	260	270	
	Effective plane area (×10 ² mm ²)	7677	7653	7627	7600	7570	7540	7508	7474	7439	7402	7363	9276	9249	9220	9189	9157	9123	9088	9051	9012	8972	8931	
	Thickness of one rubber layer (mm)	6.7											7.4											
	Number of rubber layers (-)	30											27											
	Total rubber thickness (mm)	201											200											
	First shape factor (-)	37.3											37.2											
	Second shape factor (-)	4.98											5.51											
	Diameter of flange (mm)	1400											1500											
	Thickness of flange ^{*1} (edge/center) (mm)	28/36											30/38											
	Connecting bolt PCD (mm)	1250											1350											
	Diameter of connecting bolt hole × qty (mm)	Ø 39 × 12											Ø 39 × 12											
	Bolt size (assumption) (-)	M36											M36											
	Thickness of each reinforced steel plate (mm)	4.4											4.4											
	Total height (mm)	400.6											390.2											
Total weight (tonf)	1.82	1.82	1.83	1.84	1.85	1.86	1.86	1.87	1.88	1.89	1.90	2.11	2.12	2.13	2.14	2.15	2.15	2.16	2.17	2.18	2.20	2.21		
Total weight (kN)	17.8	17.9	18.0	18.0	18.1	18.2	18.3	18.4	18.5	18.6	18.7	20.7	20.8	20.9	21.0	21.0	21.1	21.2	21.3	21.4	21.5	21.6		
Compression Properties	Critical stress (N/mm ²)	80											89											
	Ultimate compressive stress (N/mm ²)	(γ ₀ , σ ₀)	(0.00,60)											(0.00,60)										
		(γ ₁ , σ ₁)	(1.40,60)											(2.01,60)										
		(γ ₂ , σ ₂)	(4.00,22)											(4.00,31)										
	Compressive stiffness (×10 ³ kN/m)	4610											5600											
	Nominal long term compressive stress (N/mm ²)	15.0											15.0											
	Nominal long term column load (kN)	11500	11500	11400	11400	11400	11300	11300	11200	11200	11100	11000	13900	13900	13800	13800	13700	13700	13600	13600	13500	13500	13400	
Allowable tensile stress (γ = 100%) (N/mm ²)	1.0											1.0												
Shear Properties (γ = 100%)	Initial stiffness (×10 ³ kN/m)	19.8	19.8	19.8	19.9	19.9	20.0	20.0	20.0	20.1	20.1	20.2	24.1	24.1	24.2	24.2	24.3	24.3	24.3	24.4	24.4	24.5	24.5	
	Post yield stiffness (γ = 100%) (×10 ³ kN/m)	1.52	1.52	1.53	1.53	1.53	1.54	1.54	1.54	1.55	1.55	1.55	1.85	1.86	1.86	1.86	1.87	1.87	1.87	1.88	1.88	1.88	1.89	
	Characteristic Strength (kN)	141	160	181	203	226	250	276	303	331	360	391	181	203	226	250	276	303	331	360	391	423	456	
	Equivalent shear stiffness (×10 ³ kN/m)	2.22	2.32	2.43	2.54	2.66	2.78	2.91	3.05	3.19	3.34	3.50	2.76	2.87	2.99	3.12	3.25	3.38	3.53	3.68	3.84	4.00	4.17	
	Equivalent damping ratio (-)	0.193	0.209	0.224	0.239	0.253	0.266	0.278	0.289	0.299	0.309	0.317	0.200	0.215	0.229	0.242	0.254	0.266	0.277	0.287	0.297	0.305	0.313	

* : Special thickness for flange is available. Please refer to the table above for more details.

Certification number MVBR-0517

●LH Series (Total Rubber Thickness 20cm)

Characteristics		LH120G4													
		S	F	E	D	C	B	A	G	H	I	J	K	L	
Physical Dimensions	Outer diameter (mm)	1200													
	Lead plug diameter (mm)	180	190	200	210	220	230	240	250	260	270	280	290	300	
	Effective plane area ($\times 10^2$ mm ²)	11055	11026	10996	10963	10930	10894	10857	10819	10779	10737	10694	10649	10603	
	Thickness of one rubber layer (mm)	8.0													
	Number of rubber layers (-)	25													
	Total rubber thickness (mm)	200													
	First shape factor (-)	37.5													
	Second shape factor (-)	6.00													
	Diameter of flange (mm)	1600													
	Thickness of flange* ¹ (edge/center) (mm)	32/40													
	Connecting bolt PCD (mm)	1450													
	Diameter of connecting bolt hole \times qty (mm)	$\varnothing 39 \times 12$													
	Bolt size (assumption) (-)	M36													
	Thickness of each reinforced steel plate (mm)	4.4													
	Total height (mm)	385.6													
Total weight (tonf)	2.45	2.46	2.47	2.47	2.48	2.49	2.50	2.51	2.52	2.53	2.55	2.56	2.57		
Total weight (kN)	24.0	24.1	24.2	24.3	24.3	24.4	24.5	24.6	24.7	24.9	25.0	25.1	25.2		
Compression Properties	Critical stress (N/mm ²) σ_{cr} when $\gamma = 0$	98													
	Ultimate compressive stress (N/mm ²)	(γ_0, σ_0)	(0.00,60)												
		(γ_1, σ_1)	(2.58,60)												
		(γ_2, σ_2)	(4.00,39)												
	Compressive stiffness ($\times 10^3$ kN/m)	6690													
	Nominal long term compressive stress (N/mm ²)	15.0													
	Nominal long term column load (kN)	16600	16500	16500	16400	16400	16300	16300	16200	16200	16100	16000	16000	15900	
Allowable tensile stress ($\gamma = 100\%$) (N/mm ²)	1.0														
Shear Properties ($\gamma = 100\%$)	Initial stiffness ($\times 10^3$ kN/m)	28.6	28.7	28.7	28.7	28.8	28.8	28.9	28.9	29.0	29.0	29.1	29.2	29.2	
	Post yield stiffness ($\gamma = 100\%$) ($\times 10^3$ kN/m)	2.20	2.21	2.21	2.21	2.21	2.22	2.22	2.23	2.23	2.23	2.24	2.24	2.25	
	Characteristic Strength (kN)	203	226	250	276	303	331	360	391	423	456	491	526	563	
	Equivalent shear stiffness ($\times 10^3$ kN/m)	3.22	3.33	3.46	3.59	3.73	3.87	4.02	4.18	4.34	4.51	4.69	4.87	5.06	
	Equivalent damping ratio (-)	0.193	0.206	0.219	0.232	0.244	0.255	0.266	0.276	0.285	0.294	0.302	0.310	0.317	

* : Special thickness for flange is available. Please refer to the table on the next page (upper top table) for more details.

Specification of flange (edge thickness / center thickness)

Outer diameter of rubber bearing (Ø) ^{*1}	(600)	(650)	700	750	800	850	900	950	1000	1100	1200	1300
Standard thickness	22/28	22/28	22/28	22/28	24/32	24/32	28/36	28/36	28/36	30/38	32/40	32/40
Special thickness (option)	(26/32)	(26/32)	26/32	30/36	32/40	32/40	37/45	37/45	42/50	42/50	42/50	42/50

*1 For adoption of special thickness in regard to those sizes that stated in the (), delivery time will be longer due to mold preparation.

*2 For Ø1400 and above, assembled type flange will be used.

*3 Compared to the standard specification, total height & weight of product for special thickness will be changed.

Certification number MVBR-0517

●LH Series (Total Rubber Thickness 20cm)

Characteristics		LH130G4													
		S	F	E	D	C	B	A	G	H	I	J	K	L	
Physical Dimensions	Outer diameter (mm)	1300													
	Lead plug diameter (mm)	200	210	220	230	240	250	260	270	280	290	300	310	320	
	Effective plane area (×10 ² mm ²)	12959	12927	12893	12858	12821	12782	12742	12701	12657	12613	12566	12518	12469	
	Thickness of one rubber layer (mm)	8.7													
	Number of rubber layers (-)	23													
	Total rubber thickness (mm)	200													
	First shape factor (-)	37.4													
	Second shape factor (-)	6.50													
	Diameter of flange (mm)	1700													
	Thickness of flange ^{*1} (edge/center) (mm)	32/40													
	Connecting bolt PCD (mm)	1550													
	Diameter of connecting bolt hole × qty (mm)	Ø39 × 12													
	Bolt size (assumption) (-)	M36													
	Thickness of each reinforced steel plate (mm)	4.4													
	Total height (mm)	376.9													
Total weight (tonf)	2.74	2.75	2.76	2.77	2.78	2.79	2.80	2.81	2.82	2.83	2.84	2.86	2.87		
Total weight (kN)	26.9	26.9	27.0	27.1	27.2	27.3	27.4	27.5	27.6	27.8	27.9	28.0	28.1		
Compression Properties	Critical stress (N/mm ²)	106													
	Ultimate compressive stress (N/mm ²)	[γ ₀ , σ ₀]													
		[γ ₁ , σ ₁]													
		[γ ₂ , σ ₂]													
	Compressive stiffness (×10 ³ kN/m)	7830													
	Nominal long term compressive stress (N/mm ²)	15.0													
	Nominal long term column load (kN)	19400	19400	19300	19300	19200	19200	19100	19100	19000	18900	18800	18800	18700	
Shear Properties (γ = 100%)	Allowable tensile stress (γ = 100%) (N/mm ²)	1.0													
	Initial stiffness (×10 ³ kN/m)	33.6	33.6	33.7	33.7	33.8	33.8	33.9	33.9	34.0	34.0	34.1	34.2	34.2	
	Post yield stiffness (γ = 100%) (×10 ³ kN/m)	2.58	2.59	2.59	2.59	2.60	2.60	2.61	2.61	2.61	2.62	2.62	2.63	2.63	
	Characteristic Strength (kN)	250	276	303	331	360	391	423	456	491	526	563	601	641	
	Equivalent shear stiffness (×10 ³ kN/m)	3.84	3.97	4.10	4.25	4.40	4.56	4.72	4.89	5.07	5.25	5.44	5.63	5.84	
Equivalent damping ratio (-)	0.199	0.211	0.223	0.235	0.246	0.256	0.266	0.275	0.284	0.292	0.300	0.307	0.314		

* : Special thickness for flange is available. Please refer to the table above for more details.

Certification number MVBR-0517

●LH Series (Total Rubber Thickness 20cm)

Characteristics		LH140G4														
		T	S	F	E	D	C	B	A	G	H	I	J	K	L	
Physical Dimensions	Outer diameter (mm)	1400														
	Lead plug diameter (mm)	210	220	230	240	250	260	270	280	290	300	310	320	330	340	
	Effective plane area ($\times 10^2 \text{ mm}^2$)	15047	15014	14978	14941	14903	14863	14821	14778	14733	14687	14639	14590	14539	14486	
	Thickness of one rubber layer (mm)	9.5														
	Number of rubber layers (-)	21														
	Total rubber thickness (mm)	200														
	First shape factor (-)	36.8														
	Second shape factor (-)	7.02														
	Diameter of flange (mm)	1800														
	Thickness of flange (edge/center) (mm)	50/100														
	Connecting bolt PCD (mm)	1650														
	Diameter of connecting bolt hole \times qty (mm)	$\varnothing 42 \times 12$														
	Bolt size (assumption) (-)	M39														
	Thickness of each reinforced steel plate (mm)	5.8														
	Total height (mm)	515.5														
Total weight (tonf)	5.22	5.23	5.23	5.25	5.26	5.27	5.28	5.29	5.30	5.32	5.33	5.34	5.36	5.37		
Total weight (kN)	51.1	51.2	51.3	51.4	51.5	51.6	51.8	51.9	52.0	52.1	52.3	52.4	52.5	52.7		
Compression Properties	Critical stress (N/mm^2) σ_{cr} when $\gamma = 0$	114														
	Ultimate compressive stress (N/mm^2)	(γ'_0, σ_0)	(0.00,60)													
		(γ'_1, σ_1)	(3.68,60)													
		(γ'_2, σ_2)	(4.00,55)													
	Compressive stiffness ($\times 10^3 \text{ kN}/\text{m}$)	9060														
	Nominal long term compressive stress (N/mm^2)	15.0														
	Nominal long term column load (kN)	22600	22500	22500	22400	22400	22300	22200	22200	22100	22000	22000	21900	21800	21700	
Allowable tensile stress ($\gamma = 100\%$) (N/mm^2)	1.0															
Shear Properties ($\gamma = 100\%$)	Initial stiffness ($\times 10^3 \text{ kN}/\text{m}$)	39.1	39.1	39.2	39.2	39.3	39.3	39.4	39.4	39.5	39.5	39.6	39.7	39.7	39.8	
	Post yield stiffness ($\gamma = 100\%$) ($\times 10^3 \text{ kN}/\text{m}$)	3.01	3.01	3.01	3.02	3.02	3.02	3.03	3.03	3.04	3.04	3.05	3.05	3.06	3.06	
	Characteristic Strength (kN)	276	303	331	360	391	423	456	491	526	563	601	641	681	723	
	Equivalent shear stiffness ($\times 10^3 \text{ kN}/\text{m}$)	4.39	4.53	4.67	4.82	4.98	5.14	5.31	5.49	5.67	5.86	6.06	6.26	6.47	6.69	
	Equivalent damping ratio (-)	0.193	0.205	0.216	0.227	0.237	0.247	0.257	0.266	0.275	0.283	0.291	0.298	0.305	0.311	

Certification number MVBR-0517

●LH Series (Total Rubber Thickness 20cm)

Characteristics		LH150G4														
		T	S	F	E	D	C	B	A	G	H	I	J	K	L	M
Physical Dimensions	Outer diameter (mm)	1500														
	Lead plug diameter (mm)	230	240	250	260	270	280	290	300	310	320	330	340	350	360	370
	Effective plane area ($\times 10^2$ mm ²)	17256	17219	17181	17141	17099	17056	17011	16965	16917	16867	16816	16764	16709	16654	16596
	Thickness of one rubber layer (mm)	10.0														
	Number of rubber layers (-)	20														
	Total rubber thickness (mm)	200														
	First shape factor (-)	37.5														
	Second shape factor (-)	7.50														
	Diameter of flange (mm)	1900														
	Thickness of flange (edge/center) (mm)	50/100														
	Connecting bolt PCD (mm)	1750														
	Diameter of connecting bolt hole \times qty (mm)	$\varnothing 42 \times 16$														
	Bolt size (assumption) (-)	M39														
	Thickness of each reinforced steel plate (mm)	5.8														
	Total height (mm)	510.2														
Total weight (tonf)	5.76	5.77	5.78	5.79	5.80	5.81	5.82	5.84	5.85	5.86	5.88	5.89	5.91	5.92	5.94	
Total weight (kN)	56.4	56.5	56.6	56.8	56.9	57.0	57.1	57.2	57.4	57.5	57.6	57.8	57.9	58.1	58.2	
Compression Properties	Critical stress (N/mm ²) σ_{cr} when $\gamma = 0$	122														
	Ultimate compressive stress (N/mm ²)	(γ_0', σ_0)	(0.00,60)													
		(γ_1', σ_1)	(4.00,60)													
		(γ_2', σ_2)	(4.00,60)													
	Compressive stiffness ($\times 10^3$ kN/m)	10400														
	Nominal long term compressive stress (N/mm ²)	15.0														
	Nominal long term column load (kN)	25900	25800	25800	25700	25600	25600	25500	25400	25400	25300	25200	25100	25100	25000	24900
Allowable tensile stress ($\gamma = 100\%$) (N/mm ²)	1.0															
Shear Properties ($\gamma = 100\%$)	Initial stiffness ($\times 10^3$ kN/m)	44.8	44.8	44.9	44.9	45.0	45.0	45.1	45.1	45.2	45.3	45.3	45.4	45.5	45.5	45.6
	Post yield stiffness ($\gamma = 100\%$) ($\times 10^3$ kN/m)	3.44	3.45	3.45	3.45	3.46	3.46	3.47	3.47	3.48	3.48	3.49	3.49	3.50	3.50	3.51
	Characteristic Strength (kN)	331	360	391	423	456	491	526	563	601	641	681	723	767	811	857
	Equivalent shear stiffness ($\times 10^3$ kN/m)	5.10	5.25	5.41	5.57	5.74	5.92	6.10	6.29	6.48	6.69	6.89	7.11	7.33	7.56	7.79
	Equivalent damping ratio (-)	0.198	0.209	0.219	0.229	0.239	0.248	0.257	0.266	0.274	0.282	0.289	0.296	0.302	0.309	0.314

* : Special thickness for flange is available. Please contact us for more details.

Certification number MVBR-0517

Code

Compound name	Rubber code	Shear modulus [N/mm ²]
G4	GO.40	0.385

●LL Series (Total Rubber Thickness 16cm)

Characteristics		LL060G4										LL065G4											
		E	D	C	B	A	G	H	I	J	E	D	C	B	A	G	H	I	J				
Physical Dimensions	Outer diameter (mm)	600										650											
	Lead plug diameter (mm)	80	90	100	110	120	130	140	150	160	90	100	110	120	130	140	150	160	170				
	Effective plane area (×10 ² mm ²)	2777	2764	2749	2732	2714	2695	2673	2651	2626	3255	3240	3223	3205	3186	3164	3142	3117	3091				
	Thickness of one rubber layer (mm)	3.95										4.4											
	Number of rubber layers	41										37											
	Total rubber thickness (mm)	162										163											
	First shape factor	38.0										36.9											
	Second shape factor	3.70										3.99											
	Diameter of flange (mm)	900										950											
	Thickness of flange (edge/center) (mm)	22/28										22/28											
	Connecting bolt PCD (mm)	775										825											
	Diameter of connecting bolt hole × qty	∅ 33 × 12										∅ 33 × 12											
	Bolt size (assumption)	M30										M30											
	Thickness of each reinforced steel plate (mm)	3.1										3.1											
	Total height (mm)	342.0										330.4											
Total weight (tonf)	0.60	0.60	0.60	0.61	0.61	0.61	0.62	0.62	0.63	0.65	0.66	0.66	0.66	0.67	0.67	0.68	0.68	0.69					
Total weight (kN)	5.8	5.9	5.9	5.9	6.0	6.0	6.1	6.1	6.2	6.4	6.4	6.5	6.5	6.6	6.6	6.7	6.7	6.8					
Compression Properties	Critical stress [N/mm ²]	σ_{cr} when $\gamma = 0$		41										48									
	Ultimate compressive stress [N/mm ²]	(γ_0, σ_0)		(0.00,41)										(0.00,48)									
		(γ_1, σ_1)		(0.00,41)										(0.00,48)									
		(γ_2, σ_2)		(3.70,4)										(3.99,5)									
	Compressive stiffness (×10 ³ kN/m)	2070										2400											
	Nominal long term compressive stress [N/mm ²]	9.2										10.5											
	Nominal long term column load (kN)	2550	2540	2520	2510	2490	2470	2460	2430	2410	3410	3400	3380	3360	3340	3320	3290	3270	3240				
Allowable tensile stress [$\gamma = 100\%$] [N/mm ²]	1.0										1.0												
Shear Properties [$\gamma = 100\%$]	Initial stiffness (×10 ³ kN/m)	8.82	8.84	8.86	8.89	8.92	8.95	8.98	9.02	9.06	10.3	10.3	10.4	10.4	10.4	10.4	10.5	10.5	10.6				
	Post yield stiffness [$\gamma = 100\%$] (×10 ³ kN/m)	0.678	0.680	0.682	0.684	0.686	0.688	0.691	0.694	0.697	0.792	0.794	0.796	0.798	0.801	0.803	0.806	0.809	0.812				
	Characteristic Strength (kN)	40.0	50.7	62.6	75.7	90.1	106	123	141	160	50.7	62.6	75.7	90.1	106	123	141	160	181				
	Equivalent shear stiffness (×10 ³ kN/m)	0.926	0.993	1.07	1.15	1.24	1.34	1.45	1.56	1.69	1.10	1.18	1.26	1.35	1.45	1.56	1.67	1.79	1.92				
	Equivalent damping ratio	0.165	0.193	0.219	0.244	0.266	0.285	0.302	0.317	0.329	0.174	0.199	0.223	0.246	0.266	0.284	0.300	0.314	0.326				

Certification number MVBR-0517

●LL Series (Total Rubber Thickness 16cm)

Characteristics		LLO70G4										LLO75G4											
		E	D	C	B	A	G	H	I	J	E	D	C	B	A	G	H	I	J				
Physical Dimensions	Outer diameter (mm)	700										750											
	Lead plug diameter (mm)	100	110	120	130	140	150	160	170	180	110	120	130	140	150	160	170	180	190				
	Effective plane area ($\times 10^2$ mm ²)	3770	3753	3735	3716	3695	3672	3647	3621	3594	4323	4305	4285	4264	4241	4217	4191	4163	4134				
	Thickness of one rubber layer (mm)	4.9										4.85											
	Number of rubber layers (-)	34										34											
	Total rubber thickness (mm)	167										165											
	First shape factor (-)	35.7										38.7											
	Second shape factor (-)	4.20										4.55											
	Diameter of flange (mm)	1000										1100											
	Thickness of flange (edge/center) (mm)	22/28										22/28											
	Connecting bolt PCD (mm)	875										950											
	Diameter of connecting bolt hole \times qty (mm)	$\varnothing 33 \times 12$										$\varnothing 33 \times 12$											
	Bolt size (assumption) (-)	M30										M30											
	Thickness of each reinforced steel plate (mm)	3.1										3.1											
	Total height (mm)	324.9										323.2											
Total weight (tonf)	0.72	0.72	0.73	0.73	0.74	0.74	0.75	0.75	0.76	0.84	0.85	0.85	0.85	0.86	0.86	0.87	0.88	0.88					
Total weight (kN)	7.0	7.1	7.1	7.2	7.2	7.3	7.3	7.4	7.4	8.2	8.3	8.3	8.4	8.4	8.5	8.5	8.6	8.7					
Compression Properties	Critical stress (N/mm ²)	σ_{cr} when $\gamma = 0$		54										67									
	Ultimate compressive stress (N/mm ²)	(γ_0', σ_0)		(0.00,54)										(0.00,60)									
		(γ_1', σ_1)		(0.00,54)										(0.50,60)									
		(γ_2', σ_2)		(4.00,8)										(4.00,14)									
	Compressive stiffness ($\times 10^3$ kN/m)	2680										3200											
	Nominal long term compressive stress (N/mm ²)	11.4										13.0											
	Nominal long term column load (kN)	4310	4290	4270	4250	4220	4200	4170	4140	4110	5620	5590	5570	5540	5510	5480	5440	5410	5370				
Allowable tensile stress ($\gamma = 100\%$) (N/mm ²)	1.0										1.0												
Shear Properties ($\gamma = 100\%$)	Initial stiffness ($\times 10^3$ kN/m)	11.7	11.7	11.7	11.8	11.8	11.8	11.9	11.9	12.0	13.6	13.6	13.6	13.6	13.7	13.7	13.8	13.8	13.9				
	Post yield stiffness ($\gamma = 100\%$) ($\times 10^3$ kN/m)	0.899	0.901	0.903	0.905	0.908	0.910	0.913	0.916	0.920	1.04	1.05	1.05	1.05	1.05	1.06	1.06	1.06	1.07				
	Characteristic Strength (kN)	62.6	75.7	90.1	106	123	141	160	181	203	75.7	90.1	106	123	141	160	181	203	226				
	Equivalent shear stiffness ($\times 10^3$ kN/m)	1.27	1.36	1.44	1.54	1.64	1.76	1.87	2.00	2.14	1.50	1.59	1.69	1.79	1.91	2.03	2.16	2.29	2.44				
	Equivalent damping ratio (-)	0.181	0.205	0.227	0.247	0.266	0.283	0.298	0.311	0.323	0.187	0.209	0.229	0.248	0.266	0.282	0.296	0.309	0.320				

Certification number MVBR-0517

●LL Series (Total Rubber Thickness 16cm)

Characteristics		LL080G4										LL085G4											
		E	D	C	B	A	G	H	I	J	F	E	D	C	B	A	G	H	I	J	K		
Physical Dimensions	Outer diameter (mm)	800										850											
	Lead plug diameter (mm)	120	130	140	150	160	170	180	190	200	120	130	140	150	160	170	180	190	200	210	220		
	Effective plane area ($\times 10^2 \text{ mm}^2$)	4913	4894	4873	4850	4825	4800	4772	4743	4712	5561	5542	5521	5498	5473	5448	5420	5391	5360	5328	5294		
	Thickness of one rubber layer (mm)	5.1										5.25											
	Number of rubber layers (-)	33										32											
	Total rubber thickness (mm)	168										168											
	First shape factor (-)	39.2										40.5											
	Second shape factor (-)	4.75										5.06											
	Diameter of flange (mm)	1150										1200											
	Thickness of flange (edge/center) (mm)	24/32										24/32											
	Connecting bolt PCD (mm)	1000										1050											
	Diameter of connecting bolt hole \times qty (mm)	$\varnothing 33 \times 12$										$\varnothing 33 \times 12$											
	Bolt size (assumption) (-)	M30										M30											
	Thickness of each reinforced steel plate (mm)	4.4										4.4											
	Total height (mm)	373.1										368.4											
Total weight (tonf)	1.15	1.16	1.16	1.17	1.17	1.18	1.19	1.19	1.20	1.26	1.26	1.27	1.28	1.28	1.29	1.29	1.30	1.31	1.32	1.32			
Total weight (kN)	11.3	11.3	11.4	11.4	11.5	11.6	11.6	11.7	11.8	12.4	12.4	12.5	12.5	12.6	12.6	12.7	12.8	12.8	12.9	13.0			
Compression Properties	Critical stress (N/mm^2)	σ_{cr} when $\gamma = 0$		74										85									
	Ultimate compressive stress (N/mm^2)	(γ'_0, σ_0)		(0.00,60)										(0.00,60)									
		(γ'_1, σ_1)		(1.00,60)										(1.65,60)									
		(γ'_2, σ_2)		(4.00,18)										(4.00,24)									
	Compressive stiffness ($\times 10^3 \text{ kN}/\text{m}$)	3590										4100											
	Nominal long term compressive stress (N/mm^2)	13.0										15.0											
	Nominal long term column load (kN)	6390	6360	6330	6300	6270	6240	6200	6170	6130	8340	8310	8280	8250	8210	8170	8130	8090	8040	7990	7940		
Allowable tensile stress ($\gamma = 100\%$) (N/mm^2)	1.0										1.0												
Shear Properties ($\gamma = 100\%$)	Initial stiffness ($\times 10^3 \text{ kN}/\text{m}$)	15.1	15.2	15.2	15.2	15.3	15.3	15.3	15.4	15.4	17.1	17.1	17.1	17.2	17.2	17.3	17.3	17.3	17.4	17.4	17.5		
	Post yield stiffness ($\gamma = 100\%$) ($\times 10^3 \text{ kN}/\text{m}$)	1.16	1.17	1.17	1.17	1.17	1.18	1.18	1.18	1.19	1.31	1.32	1.32	1.32	1.32	1.33	1.33	1.33	1.34	1.34	1.35		
	Characteristic Strength (kN)	90.1	106	123	141	160	181	203	226	250	90.1	106	123	141	160	181	203	226	250	276	303		
	Equivalent shear stiffness ($\times 10^3 \text{ kN}/\text{m}$)	1.70	1.79	1.90	2.01	2.13	2.25	2.38	2.53	2.67	1.85	1.95	2.05	2.16	2.28	2.40	2.54	2.68	2.83	2.98	3.15		
	Equivalent damping ratio (-)	0.193	0.213	0.232	0.250	0.266	0.281	0.294	0.306	0.317	0.178	0.198	0.216	0.234	0.251	0.266	0.280	0.293	0.304	0.315	0.324		

Certification number MVBR-0517

●LL Series (Total Rubber Thickness 16cm)

Characteristics		LL090G4											LL095G4												
		F	E	D	C	B	A	G	H	I	J	K	F	E	D	C	B	A	G	H	I	J	K		
Physical Dimensions	Outer diameter (mm)	900											950												
	Lead plug diameter (mm)	130	140	150	160	170	180	190	200	210	220	230	140	150	160	170	180	190	200	210	220	230	240		
	Effective plane area ($\times 10^2 \text{ mm}^2$)	6229	6208	6185	6161	6135	6107	6078	6048	6015	5982	5946	6934	6912	6887	6861	6834	6805	6774	6742	6708	6673	6636		
	Thickness of one rubber layer (mm)	5.65											6.00												
	Number of rubber layers (-)	30											28												
	Total rubber thickness (mm)	170											168												
	First shape factor (-)	39.8											39.6												
	Second shape factor (-)	5.31											5.65												
	Diameter of flange (mm)	1250											1300												
	Thickness of flange (edge/center) (mm)	28/36											28/36												
	Connecting bolt PCD (mm)	1100											1150												
	Diameter of connecting bolt hole \times qty (mm)	$\varnothing 33 \times 12$											$\varnothing 33 \times 12$												
	Bolt size (assumption) (-)	M30											M30												
	Thickness of each reinforced steel plate (mm)	4.4											4.4												
	Total height (mm)	369.1											358.8												
Total weight (tonf)	1.43	1.44	1.44	1.45	1.45	1.46	1.47	1.48	1.48	1.49	1.50	1.53	1.54	1.54	1.55	1.55	1.56	1.57	1.58	1.58	1.59	1.60			
Total weight (kN)	14.0	14.1	14.1	14.2	14.3	14.3	14.4	14.5	14.6	14.6	14.7	15.0	15.1	15.1	15.2	15.2	15.3	15.4	15.5	15.5	15.6	15.7			
Compression Properties	Critical stress (N/mm^2)	σ_{cr} when $\gamma = 0$		89											94										
	Ultimate compressive stress (N/mm^2)	(γ_0', σ_0)		(0.00,60)											(0.00,60)										
		(γ_1', σ_1)		(1.90,60)											(2.28,60)										
		(γ_2', σ_2)		(4.00,29)											(4.00,34)										
	Compressive stiffness ($\times 10^3 \text{ kN}/\text{m}$)	4530											5080												
	Nominal long term compressive stress (N/mm^2)	15.0											15.0												
	Nominal long term column load (kN)	9340	9310	9280	9240	9200	9160	9120	9070	9020	8970	8920	10400	10400	10300	10300	10300	10200	10200	10100	10100	10000	10000		
Allowable tensile stress ($\gamma = 100\%$) (N/mm^2)	1.0											1.0													
Shear Properties ($\gamma = 100\%$)	Initial stiffness ($\times 10^3 \text{ kN}/\text{m}$)	19.0	19.0	19.1	19.1	19.1	19.2	19.2	19.3	19.3	19.4	19.4	21.4	21.4	21.4	21.5	21.5	21.6	21.6	21.6	21.7	21.8	21.8		
	Post yield stiffness ($\gamma = 100\%$) ($\times 10^3 \text{ kN}/\text{m}$)	1.46	1.46	1.47	1.47	1.47	1.47	1.48	1.48	1.49	1.49	1.49	1.64	1.65	1.65	1.65	1.65	1.66	1.66	1.67	1.67	1.67	1.68		
	Characteristic Strength (kN)	106	123	141	160	181	203	226	250	276	303	331	123	141	160	181	203	226	250	276	303	331	360		
	Equivalent shear stiffness ($\times 10^3 \text{ kN}/\text{m}$)	2.08	2.19	2.30	2.41	2.54	2.67	2.81	2.96	3.11	3.28	3.45	2.37	2.48	2.60	2.73	2.86	3.00	3.15	3.31	3.47	3.64	3.82		
	Equivalent damping ratio (-)	0.184	0.202	0.219	0.236	0.251	0.266	0.279	0.291	0.302	0.312	0.321	0.189	0.206	0.222	0.238	0.252	0.266	0.278	0.290	0.301	0.310	0.319		

Certification number MVBR-0517

●LL Series (Total Rubber Thickness 16cm)

Characteristics		LL100G4											LL110G4												
		F	E	D	C	B	A	G	H	I	J	K	F	E	D	C	B	A	G	H	I	J	K		
Physical Dimensions	Outer diameter (mm)	1000											1100												
	Lead plug diameter (mm)	150	160	170	180	190	200	210	220	230	240	250	170	180	190	200	210	220	230	240	250	260	270		
	Effective plane area ($\times 10^2$ mm ²)	7677	7653	7627	7600	7570	7540	7508	7474	7439	7402	7363	9276	9249	9220	9189	9157	9123	9088	9051	9012	8972	8931		
	Thickness of one rubber layer (mm)	6.35											7.2												
	Number of rubber layers (-)	26											23												
	Total rubber thickness (mm)	165											166												
	First shape factor (-)	39.4											38.2												
	Second shape factor (-)	6.06											6.64												
	Diameter of flange (mm)	1400											1500												
	Thickness of flange (edge/center) (mm)	28/36											30/38												
	Connecting bolt PCD (mm)	1250											1350												
	Diameter of connecting bolt hole \times qty (mm)	$\varnothing 39 \times 12$											$\varnothing 39 \times 12$												
	Bolt size (assumption) (-)	M36											M36												
	Thickness of each reinforced steel plate (mm)	4.4											4.4												
	Total height (mm)	347.1											338.4												
Total weight (tonf)	1.66	1.67	1.67	1.68	1.69	1.69	1.70	1.71	1.72	1.73	1.73	1.93	1.94	1.95	1.95	1.96	1.97	1.98	1.98	1.99	2.01	2.01			
Total weight (kN)	16.3	16.4	16.4	16.5	16.5	16.6	16.7	16.8	16.8	16.9	17.0	19.0	19.0	19.1	19.2	19.2	19.3	19.4	19.5	19.6	19.7	19.7			
Compression Properties	Critical stress (N/mm ²)	σ_{cr} when $\gamma = 0$		101											109										
	Ultimate compressive stress (N/mm ²)	(γ'_0, σ_0)		(0.00,60)											(0.00,60)										
		(γ'_1, σ_1)		(2.72,60)											(3.32,60)										
		(γ'_2, σ_2)		(4.00,41)											(4.00,50)										
	Compressive stiffness ($\times 10^3$ kN/m)	5720											6830												
	Nominal long term compressive stress (N/mm ²)	15.0											15.0												
	Nominal long term column load (kN)	11500	11500	11400	11400	11400	11300	11300	11200	11200	11100	11100	13900	13900	13800	13800	13700	13700	13600	13600	13500	13500	13400		
Allowable tensile stress ($\gamma = 100\%$) (N/mm ²)	1.0											1.0													
Shear Properties ($\gamma = 100\%$)	Initial stiffness ($\times 10^3$ kN/m)	24.1	24.1	24.2	24.2	24.3	24.3	24.3	24.4	24.5	24.5	24.6	29.1	29.1	29.2	29.2	29.3	29.3	29.4	29.4	29.5	29.5	29.6		
	Post yield stiffness ($\gamma = 100\%$) ($\times 10^3$ kN/m)	1.85	1.86	1.86	1.86	1.87	1.87	1.87	1.88	1.88	1.89	1.89	2.24	2.24	2.24	2.25	2.25	2.25	2.26	2.26	2.27	2.27	2.28		
	Characteristic Strength (kN)	141	160	181	203	226	250	276	303	331	360	391	181	203	226	250	276	303	331	360	391	423	456		
	Equivalent shear stiffness ($\times 10^3$ kN/m)	2.71	2.83	2.95	3.09	3.23	3.39	3.54	3.71	3.89	4.07	4.26	3.33	3.46	3.61	3.76	3.92	4.08	4.26	4.44	4.63	4.83	5.03		
	Equivalent damping ratio (-)	0.193	0.209	0.224	0.239	0.253	0.266	0.278	0.289	0.299	0.309	0.317	0.200	0.215	0.229	0.242	0.254	0.266	0.277	0.287	0.297	0.305	0.313		

Certification number MVBR-0517

●LL Series (Total Rubber Thickness 16cm)

Characteristics		LL120G4												
		S	F	E	D	C	B	A	G	H	I	J	K	L
Physical Dimensions	Outer diameter (mm)	1200												
	Lead plug diameter (mm)	180	190	200	210	220	230	240	250	260	270	280	290	300
	Effective plane area ($\times 10^2$ mm ²)	11055	11026	10996	10963	10930	10894	10857	10819	10779	10737	10694	10649	10603
	Thickness of one rubber layer (mm)	7.7												
	Number of rubber layers (-)	22												
	Total rubber thickness (mm)	169												
	First shape factor (-)	39.0												
	Second shape factor (-)	7.08												
	Diameter of flange (mm)	1600												
	Thickness of flange (edge/center) (mm)	32/40												
	Connecting bolt PCD (mm)	1450												
	Diameter of connecting bolt hole \times qty (mm)	$\varnothing 39 \times 12$												
	Bolt size (assumption) (-)	M36												
	Thickness of each reinforced steel plate (mm)	4.4												
	Total height (mm)	341.8												
Total weight (tonf)	2.27	2.28	2.29	2.30	2.30	2.31	2.32	2.33	2.34	2.35	2.36	2.37	2.38	
Total weight (kN)	22.3	22.4	22.4	22.5	22.6	22.7	22.8	22.8	22.9	23.0	23.1	23.2	23.3	
Compression Properties	Critical stress (N/mm ²)	σ_{cr} when $\gamma = 0$												
	Ultimate compressive stress (N/mm ²)	117												
		(γ_0, σ_0)	(0.00,60)											
		(γ_1, σ_1)	(3.84,60)											
		(γ_2, σ_2)	(4.00,58)											
	Compressive stiffness ($\times 10^3$ kN/m)	8000												
	Nominal long term compressive stress (N/mm ²)	15.0												
Nominal long term column load (kN)	16600	16500	16500	16400	16400	16300	16300	16200	16200	16100	16000	16000	15900	
Allowable tensile stress ($\gamma = 100\%$) (N/mm ²)	1.0													
Shear Properties ($\gamma = 100\%$)	Initial stiffness ($\times 10^3$ kN/m)	33.8	33.8	33.9	33.9	34.0	34.0	34.1	34.2	34.2	34.3	34.4	34.4	34.5
	Post yield stiffness ($\gamma = 100\%$) ($\times 10^3$ kN/m)	2.60	2.60	2.61	2.61	2.61	2.62	2.62	2.63	2.63	2.64	2.64	2.65	2.65
	Characteristic Strength (kN)	203	226	250	276	303	331	360	391	423	456	491	526	563
	Equivalent shear stiffness ($\times 10^3$ kN/m)	3.80	3.94	4.08	4.24	4.40	4.57	4.75	4.94	5.13	5.33	5.54	5.75	5.98
	Equivalent damping ratio (-)	0.193	0.206	0.219	0.232	0.244	0.255	0.266	0.276	0.285	0.294	0.302	0.310	0.317

Certification number MVBR-0517

●LL Series (Total Rubber Thickness 16cm)

Characteristics		LL130G4												
		S	F	E	D	C	B	A	G	H	I	J	K	L
Physical Dimensions	Outer diameter (mm)	1300												
	Lead plug diameter (mm)	200	210	220	230	240	250	260	270	280	290	300	310	320
	Effective plane area ($\times 10^2 \text{ mm}^2$)	12959	12927	12893	12858	12821	12782	12742	12701	12657	12613	12566	12518	12469
	Thickness of one rubber layer (mm)	8.0												
	Number of rubber layers (-)	21												
	Total rubber thickness (mm)	168												
	First shape factor (-)	40.6												
	Second shape factor (-)	7.74												
	Diameter of flange (mm)	1700												
	Thickness of flange (edge/center) (mm)	32/40												
	Connecting bolt PCD (mm)	1550												
	Diameter of connecting bolt hole \times qty (mm)	$\varnothing 39 \times 12$												
	Bolt size (assumption) (-)	M36												
	Thickness of each reinforced steel plate (mm)	5.8												
	Total height (mm)	364.0												
Total weight (tonf)	2.88	2.89	2.90	2.91	2.92	2.92	2.93	2.94	2.95	2.97	2.98	2.99	3.00	
Total weight (kN)	28.3	28.3	28.4	28.5	28.6	28.7	28.8	28.9	29.0	29.1	29.2	29.3	29.4	
Compression Properties	Critical stress (N/mm^2)	σ_{cr} when $\gamma = 0$		130										
	Ultimate compressive stress (N/mm^2)	(γ'_0, σ_0)		(0.00,60)										
		(γ'_1, σ_1)		(4.00,60)										
		(γ'_2, σ_2)		(4.00,60)										
	Compressive stiffness ($\times 10^3 \text{ kN}/\text{m}$)	9600												
	Nominal long term compressive stress (N/mm^2)	15.0												
	Nominal long term column load (kN)	19400	19400	19300	19300	19200	19200	19100	19100	19000	18900	18800	18800	18700
Shear Properties ($\gamma = 100\%$)	Allowable tensile stress ($\gamma = 100\%$) (N/mm^2)	1.0												
	Initial stiffness ($\times 10^3 \text{ kN}/\text{m}$)	40.0	40.1	40.1	40.2	40.2	40.3	40.4	40.4	40.5	40.6	40.6	40.7	40.8
	Post yield stiffness ($\gamma = 100\%$) ($\times 10^3 \text{ kN}/\text{m}$)	3.08	3.08	3.09	3.09	3.10	3.10	3.10	3.11	3.11	3.12	3.13	3.13	3.14
	Characteristic Strength (kN)	250	276	303	331	360	391	423	456	491	526	563	601	641
	Equivalent shear stiffness ($\times 10^3 \text{ kN}/\text{m}$)	4.57	4.73	4.89	5.06	5.24	5.43	5.62	5.82	6.03	6.25	6.48	6.71	6.95
Equivalent damping ratio (-)	0.199	0.211	0.223	0.235	0.246	0.256	0.266	0.275	0.284	0.292	0.300	0.307	0.314	

Specification of flange (edge thickness / center thickness)

Outer diameter of rubber bearing (Ø) ^{*1}	(900)	(950)	1000	1100	1200	1300
Standard thickness	28/36	28/36	28/36	30/38	32/40	32/40
Special thickness (option)	(37/45)	(37/45)	42/50	42/50	42/50	42/50

*1 For adoption of special thickness in regard to those sizes that stated in the (), delivery time will be longer due to mold preparation.
 *2 For Ø1400 and above, assembled type flange will be used.
 *3 Compared to the standard specification, total height & weight of product for special thickness will be changed.

Certification number MVBR-0517

Code

Compound name	Rubber code	Shear modulus (N/mm ²)
G4	G0.40	0.385

●LT Series (Total Rubber Thickness 25cm)

Characteristics		LT090G4											LT095G4										
		F	E	D	C	B	A	G	H	I	J	K	F	E	D	C	B	A	G	H	I	J	K
Physical Dimensions	Outer diameter (mm)	900											950										
	Lead plug diameter (mm)	130	140	150	160	170	180	190	200	210	220	230	140	150	160	170	180	190	200	210	220	230	240
	Effective plane area (×10 ² mm ²)	6229	6208	6185	6161	6135	6107	6078	6048	6015	5982	5946	6934	6912	6887	6861	6834	6805	6774	6742	6708	6673	6636
	Thickness of one rubber layer (mm)	6.0											6.4										
	Number of rubber layers (-)	42											39										
	Total rubber thickness (mm)	252											250										
	First shape factor (-)	37.5											37.1										
	Second shape factor (-)	3.57											3.81										
	Diameter of flange (mm)	1250											1300										
	Thickness of flange* (edge/center) (mm)	28/36											28/36										
	Connecting bolt PCD (mm)	1100											1150										
	Diameter of connecting bolt hole × qty	Ø 33 × 12											Ø 33 × 12										
	Bolt size (assumption) (-)	M30											M30										
	Thickness of each reinforced steel plate (mm)	4.4											4.4										
	Total height (mm)	504.4											488.8										
Total weight (tonf)	1.77	1.78	1.79	1.80	1.81	1.82	1.83	1.84	1.85	1.86	1.87	1.89	1.89	1.90	1.91	1.92	1.93	1.94	1.95	1.96	1.97	1.99	
Total weight (kN)	17.4	17.5	17.5	17.6	17.7	17.8	17.9	18.0	18.1	18.2	18.4	18.5	18.6	18.6	18.7	18.8	18.9	19.0	19.1	19.2	19.4	19.5	
Compression Properties	Critical stress (N/mm ²)	37											43										
	Ultimate compressive stress (N/mm ²)	[γ _{0'} , σ ₀]											[0.00,43]										
		[γ _{1'} , σ ₁]											[0.00,43]										
		[γ _{2'} , σ ₂]											[3.81,4]										
	Compressive stiffness (×10 ³ kN/m)	2980											3340										
	Nominal long term compressive stress (N/mm ²)	8.6											9.6										
	Nominal long term column load (kN)	5340	5330	5310	5290	5260	5240	5220	5190	5160	5130	5100	6680	6660	6640	6610	6590	6560	6530	6500	6470	6430	6400
Allowable tensile stress (γ = 100%) (N/mm ²)	1.0											1.0											
Shear Properties (γ = 100%)	Initial stiffness (×10 ³ kN/m)	12.8	12.8	12.8	12.8	12.9	12.9	12.9	13.0	13.0	13.0	13.1	14.4	14.4	14.4	14.4	14.5	14.5	14.5	14.6	14.6	14.6	14.7
	Post yield stiffness (γ = 100%) (×10 ³ kN/m)	0.982	0.984	0.986	0.988	0.990	0.992	0.994	0.997	0.999	1.00	1.00	1.11	1.11	1.11	1.11	1.11	1.12	1.12	1.12	1.13	1.13	
	Characteristic Strength (kN)	106	123	141	160	181	203	226	250	276	303	331	123	141	160	181	203	226	250	276	303	331	360
	Equivalent shear stiffness (×10 ³ kN/m)	1.40	1.47	1.54	1.62	1.71	1.80	1.89	1.99	2.09	2.20	2.32	1.60	1.67	1.75	1.84	1.93	2.02	2.12	2.23	2.34	2.45	2.57
	Equivalent damping ratio (-)	0.184	0.202	0.219	0.236	0.251	0.266	0.279	0.291	0.302	0.312	0.321	0.189	0.206	0.222	0.238	0.252	0.266	0.278	0.290	0.301	0.310	0.319

* : Special thickness for flange is available. Please refer to the table above for more details.

Certification number MVBR-0517

●LT Series (Total Rubber Thickness 25cm)

Characteristics		LT100G4											LT110G4											
		F	E	D	C	B	A	G	H	I	J	K	F	E	D	C	B	A	G	H	I	J	K	
Physical Dimensions	Outer diameter (mm)	1000											1100											
	Lead plug diameter (mm)	150	160	170	180	190	200	210	220	230	240	250	170	180	190	200	210	220	230	240	250	260	270	
	Effective plane area ($\times 10^2$ mm ²)	7677	7653	7627	7600	7570	7540	7508	7474	7439	7402	7363	9276	9249	9220	9189	9157	9123	9088	9051	9012	8972	8931	
	Thickness of one rubber layer (mm)	6.7											7.4											
	Number of rubber layers (-)	37											34											
	Total rubber thickness (mm)	248											252											
	First shape factor (-)	37.3											37.2											
	Second shape factor (-)	4.03											4.37											
	Diameter of flange (mm)	1400											1500											
	Thickness of flange* (edge/center) (mm)	28/36											30/38											
	Connecting bolt PCD (mm)	1250											1350											
	Diameter of connecting bolt hole \times qty (mm)	$\varnothing 39 \times 12$											$\varnothing 39 \times 12$											
	Bolt size (assumption) (-)	M36											M36											
	Thickness of each reinforced steel plate (mm)	4.4											4.4											
	Total height (mm)	478.3											472.8											
Total weight (tonf)	2.06	2.07	2.08	2.09	2.10	2.11	2.12	2.13	2.14	2.16	2.17	2.42	2.43	2.44	2.45	2.46	2.47	2.48	2.49	2.51	2.52	2.53		
Total weight (kN)	20.2	20.3	20.4	20.5	20.6	20.7	20.8	20.9	21.0	21.1	21.3	23.7	23.8	23.9	24.0	24.1	24.2	24.3	24.4	24.6	24.7	24.8		
Compression Properties	Critical stress (N/mm ²) σ_{cr} when $\gamma = 0$	50											60											
	Ultimate compressive stress (N/mm ²)	(γ_0, σ_0)	(0.00,50)											(0.00,60)										
		(γ_1, σ_1)	(0.00,50)											(0.00,60)										
		(γ_2, σ_2)	(4.00,5)											(4.00,11)										
	Compressive stiffness ($\times 10^3$ kN/m)	3740											4450											
	Nominal long term compressive stress (N/mm ²)	10.7											12.2											
	Nominal long term column load (kN)	8190	8160	8140	8110	8080	8040	8010	7970	7940	7900	7860	11300	11300	11200	11200	11200	11100	11100	11000	11000	10900	10900	
Allowable tensile stress ($\gamma = 100\%$) (N/mm ²)	1.0											1.0												
Shear Properties ($\gamma = 100\%$)	Initial stiffness ($\times 10^3$ kN/m)	16.0	16.1	16.1	16.1	16.2	16.2	16.2	16.3	16.3	16.3	16.4	19.1	19.2	19.2	19.2	19.3	19.3	19.3	19.4	19.4	19.4	19.5	
	Post yield stiffness ($\gamma = 100\%$) ($\times 10^3$ kN/m)	1.23	1.24	1.24	1.24	1.24	1.24	1.25	1.25	1.25	1.26	1.26	1.47	1.47	1.48	1.48	1.48	1.48	1.49	1.49	1.49	1.50	1.50	
	Characteristic Strength (kN)	141	160	181	203	226	250	276	303	331	360	391	181	203	226	250	276	303	331	360	391	423	456	
	Equivalent shear stiffness ($\times 10^3$ kN/m)	1.80	1.88	1.97	2.06	2.15	2.25	2.36	2.47	2.59	2.71	2.84	2.19	2.28	2.37	2.47	2.58	2.69	2.80	2.92	3.05	3.18	3.31	
	Equivalent damping ratio (-)	0.193	0.209	0.224	0.239	0.253	0.266	0.278	0.289	0.299	0.309	0.317	0.200	0.215	0.229	0.242	0.254	0.266	0.277	0.287	0.297	0.305	0.313	

* : Special thickness for flange is available. Please refer to the table on the next page [upper top table] for more details.

Specification of flange (edge thickness / center thickness)

Outer diameter of rubber bearing (Ø) ^{*1}	(900)	(950)	1000	1100	1200	1300
Standard thickness	28/36	28/36	28/36	30/38	32/40	32/40
Special thickness (option)	(37/45)	(37/45)	42/50	42/50	42/50	42/50

*1 For adoption of special thickness in regard to those sizes that stated in the (), delivery time will be longer due to mold preparation.

*2 For Ø1400 and above, assembled type flange will be used.

*3 Compared to the standard specification, total height & weight of product for special thickness will be changed.

Certification number MVBR-0517

●LT Series (Total Rubber Thickness 25cm)

Characteristics		LT120G4												
		S	F	E	D	C	B	A	G	H	I	J	K	L
Physical Dimensions	Outer diameter (mm)	1200												
	Lead plug diameter (mm)	180	190	200	210	220	230	240	250	260	270	280	290	300
	Effective plane area (×10 ² mm ²)	11055	11026	10996	10963	10930	10894	10857	10819	10779	10737	10694	10649	10603
	Thickness of one rubber layer (mm)	8.0												
	Number of rubber layers (-)	31												
	Total rubber thickness (mm)	248												
	First shape factor (-)	37.5												
	Second shape factor (-)	4.84												
	Diameter of flange (mm)	1600												
	Thickness of flange* (edge/center) (mm)	32/40												
	Connecting bolt PCD (mm)	1450												
	Diameter of connecting bolt hole × qty (mm)	Ø 39 × 12												
	Bolt size (assumption) (-)	M36												
	Thickness of each reinforced steel plate (mm)	4.4												
	Total height (mm)	460.0												
Total weight (tonf)	2.76	2.77	2.78	2.79	2.80	2.82	2.83	2.84	2.85	2.87	2.88	2.90	2.91	
Total weight (kN)	27.1	27.2	27.3	27.4	27.5	27.6	27.7	27.9	28.0	28.1	28.3	28.4	28.6	
Compression Properties	Critical stress (N/mm ²)	76												
	Ultimate compressive stress (N/mm ²)	[γ ₀ , σ ₀]												
		[γ ₁ , σ ₁]												
		[γ ₂ , σ ₂]												
	Compressive stiffness (×10 ³ kN/m)	5390												
	Nominal long term compressive stress (N/mm ²)	13.0												
	Nominal long term column load (kN)	14400	14300	14300	14300	14200	14200	14100	14100	14000	14000	13900	13800	13800
Shear Properties (γ = 100%)	Allowable tensile stress (γ = 100%) (N/mm ²)	1.0												
	Initial stiffness (×10 ³ kN/m)	23.1	23.1	23.2	23.2	23.2	23.3	23.3	23.3	23.4	23.4	23.5	23.5	23.6
	Post yield stiffness (γ = 100%) (×10 ³ kN/m)	1.78	1.78	1.78	1.78	1.79	1.79	1.79	1.79	1.80	1.80	1.80	1.81	1.81
	Characteristic Strength (kN)	203	226	250	276	303	331	360	391	423	456	491	526	563
	Equivalent shear stiffness (×10 ³ kN/m)	2.59	2.69	2.79	2.90	3.01	3.12	3.25	3.37	3.50	3.64	3.78	3.93	4.08
	Equivalent damping ratio (-)	0.193	0.206	0.219	0.232	0.244	0.255	0.266	0.276	0.285	0.294	0.302	0.310	0.317

* : Special thickness for flange is available. Please refer to the table above for more details.

Certification number MVBR-0517

●LT Series (Total Rubber Thickness 25cm)

Characteristics		LT130G4													
		S	F	E	D	C	B	A	G	H	I	J	K	L	
Physical Dimensions	Outer diameter (mm)	1300													
	Lead plug diameter (mm)	200	210	220	230	240	250	260	270	280	290	300	310	320	
	Effective plane area ($\times 10^2$ mm ²)	12959	12927	12893	12858	12821	12782	12742	12701	12657	12613	12566	12518	12469	
	Thickness of one rubber layer (mm)	8.7													
	Number of rubber layers (-)	29													
	Total rubber thickness (mm)	252													
	First shape factor (-)	37.4													
	Second shape factor (-)	5.15													
	Diameter of flange (mm)	1700													
	Thickness of flange* (edge/center) (mm)	32/40													
	Connecting bolt PCD (mm)	1550													
	Diameter of connecting bolt hole \times qty (mm)	$\varnothing 39 \times 12$													
	Bolt size (assumption) (-)	M36													
	Thickness of each reinforced steel plate (mm)	4.4													
	Total height (mm)	455.5													
Total weight (tonf)	3.12	3.13	3.14	3.15	3.16	3.18	3.19	3.20	3.22	3.23	3.25	3.26	3.28		
Total weight (kN)	30.6	30.7	30.8	30.9	31.0	31.1	31.3	31.4	31.5	31.7	31.8	32.0	32.1		
Compression Properties	Critical stress (N/mm ²) σ_{cr} when $\gamma = 0$	84													
	Ultimate compressive stress (N/mm ²)	(γ_0, σ_0)	(0.00,60)												
		(γ_1, σ_1)	(1.63,60)												
		(γ_2, σ_2)	(4.00,25)												
	Compressive stiffness ($\times 10^3$ kN/m)	6210													
	Nominal long term compressive stress (N/mm ²)	15.0													
	Nominal long term column load (kN)	19400	19400	19300	19300	19200	19200	19100	19100	19000	18900	18800	18800	18700	
Allowable tensile stress ($\gamma = 100\%$) (N/mm ²)	1.0														
Shear Properties ($\gamma = 100\%$)	Initial stiffness ($\times 10^3$ kN/m)	26.7	26.7	26.7	26.8	26.8	26.8	26.9	26.9	27.0	27.0	27.1	27.1	27.2	
	Post yield stiffness ($\gamma = 100\%$) ($\times 10^3$ kN/m)	2.05	2.05	2.06	2.06	2.06	2.06	2.07	2.07	2.07	2.08	2.08	2.08	2.09	
	Characteristic Strength (kN)	250	276	303	331	360	391	423	456	491	526	563	601	641	
	Equivalent shear stiffness ($\times 10^3$ kN/m)	3.04	3.15	3.26	3.37	3.49	3.61	3.74	3.88	4.02	4.16	4.31	4.47	4.63	
	Equivalent damping ratio (-)	0.199	0.211	0.223	0.235	0.246	0.256	0.266	0.275	0.284	0.292	0.300	0.307	0.314	

* : Special thickness for flange is available. Please refer to the table on the previous page (upper top table) for more details.

Certification number MVBR-0517

●LT Series (Total Rubber Thickness 25cm)

Characteristics		LT140G4													
		T	S	F	E	D	C	B	A	G	H	I	J	K	L
Physical Dimensions	Outer diameter (mm)	1400													
	Lead plug diameter (mm)	210	220	230	240	250	260	270	280	290	300	310	320	330	340
	Effective plane area ($\times 10^2 \text{ mm}^2$)	15047	15014	14978	14941	14903	14863	14821	14778	14733	14687	14639	14590	14539	14486
	Thickness of one rubber layer (mm)	9.5													
	Number of rubber layers (-)	26													
	Total rubber thickness (mm)	247													
	First shape factor (-)	36.8													
	Second shape factor (-)	5.67													
	Diameter of flange (mm)	1800													
	Thickness of flange (edge/center) (mm)	50/100													
	Connecting bolt PCD (mm)	1650													
	Diameter of connecting bolt hole \times qty (mm)	$\varnothing 42 \times 12$													
	Bolt size (assumption) (-)	M39													
	Thickness of each reinforced steel plate (mm)	5.8													
	Total height (mm)	592.0													
Total weight (tonf)	5.64	5.65	5.66	5.68	5.69	5.70	5.72	5.73	5.75	5.76	5.78	5.79	5.81	5.83	
Total weight (kN)	55.3	55.4	55.5	55.7	55.8	55.9	56.1	56.2	56.3	56.5	56.7	56.8	57.0	57.2	
Compression Properties	Critical stress (N/mm^2)	σ_{cr} when $\gamma = 0$	92												
	Ultimate compressive stress (N/mm^2)	(γ'_0, σ_0)	(0.00,60)												
		(γ'_1, σ_1)	(218,60)												
		(γ'_2, σ_2)	(4.00,33)												
	Compressive stiffness ($\times 10^3 \text{ kN}/\text{m}$)	7320													
	Nominal long term compressive stress (N/mm^2)	15.0													
	Nominal long term column load (kN)	22600	22500	22500	22400	22400	22300	22200	22200	22100	22000	22000	21900	21800	21700
Shear Properties ($\gamma = 100\%$)	Allowable tensile stress ($\gamma = 100\%$) (N/mm^2)	1.0													
	Initial stiffness ($\times 10^3 \text{ kN}/\text{m}$)	31.6	31.6	31.6	31.7	31.7	31.7	31.8	31.8	31.9	31.9	32.0	32.0	32.1	32.1
	Post yield stiffness ($\gamma = 100\%$) ($\times 10^3 \text{ kN}/\text{m}$)	2.43	2.43	2.43	2.44	2.44	2.44	2.45	2.45	2.45	2.46	2.46	2.46	2.47	2.47
	Characteristic Strength (kN)	276	303	331	360	391	423	456	491	526	563	601	641	681	723
	Equivalent shear stiffness ($\times 10^3 \text{ kN}/\text{m}$)	3.54	3.66	3.77	3.89	4.02	4.15	4.29	4.43	4.58	4.74	4.89	5.06	5.23	5.40
	Equivalent damping ratio (-)	0.193	0.205	0.216	0.227	0.237	0.247	0.257	0.266	0.275	0.283	0.291	0.298	0.305	0.311

Certification number MVBR-0517

●LT Series (Total Rubber Thickness 25cm)

Characteristics		LT150G4														
		T	S	F	E	D	C	B	A	G	H	I	J	K	L	M
Physical Dimensions	Outer diameter (mm)	1500														
	Lead plug diameter (mm)	230	240	250	260	270	280	290	300	310	320	330	340	350	360	370
	Effective plane area ($\times 10^2$ mm ²)	17256	17219	17181	17141	17099	17056	17011	16965	16917	16867	16816	16764	16709	16654	16596
	Thickness of one rubber layer (mm)	10.0														
	Number of rubber layers (-)	25														
	Total rubber thickness (mm)	250														
	First shape factor (-)	37.5														
	Second shape factor (-)	6.00														
	Diameter of flange (mm)	1900														
	Thickness of flange (edge/center) (mm)	50/100														
	Connecting bolt PCD (mm)	1750														
	Diameter of connecting bolt hole \times qty (mm)	$\varnothing 42 \times 16$														
	Bolt size (assumption) (-)	M39														
	Thickness of each reinforced steel plate (mm)	5.8														
	Total height (mm)	589.2														
Total weight (tonf)	6.33	6.35	6.36	6.37	6.39	6.40	6.42	6.43	6.45	6.47	6.48	6.50	6.52	6.54	6.56	
Total weight (kN)	62.1	62.2	62.4	62.5	62.6	62.8	62.9	63.1	63.2	63.4	63.6	63.8	63.9	64.1	64.3	
Compression Properties	Critical stress (N/mm ²) σ_{cr} when $\gamma = 0$	98														
	Ultimate compressive stress (N/mm ²)	(γ'_0, σ_0)	(0.00,60)													
		(γ'_1, σ_1)	(2.58,60)													
		(γ'_2, σ_2)	(4.00,39)													
	Compressive stiffness ($\times 10^3$ kN/m)	8360														
	Nominal long term compressive stress (N/mm ²)	15.0														
	Nominal long term column load (kN)	25900	25800	25800	25700	25600	25600	25500	25400	25400	25300	25200	25100	25100	25000	24900
Allowable tensile stress ($\gamma = 100\%$) (N/mm ²)	1.0															
Shear Properties ($\gamma = 100\%$)	Initial stiffness ($\times 10^3$ kN/m)	35.8	35.8	35.9	35.9	36.0	36.0	36.1	36.1	36.2	36.2	36.3	36.3	36.4	36.4	36.5
	Post yield stiffness ($\gamma = 100\%$) ($\times 10^3$ kN/m)	2.75	2.76	2.76	2.76	2.77	2.77	2.77	2.78	2.78	2.79	2.79	2.79	2.80	2.80	2.81
	Characteristic Strength (kN)	331	360	391	423	456	491	526	563	601	641	681	723	767	811	857
	Equivalent shear stiffness ($\times 10^3$ kN/m)	4.08	4.20	4.32	4.46	4.59	4.73	4.88	5.03	5.19	5.35	5.51	5.69	5.86	6.05	6.23
	Equivalent damping ratio (-)	0.198	0.209	0.219	0.229	0.239	0.248	0.257	0.266	0.274	0.282	0.289	0.296	0.302	0.309	0.314

Certification number MVBR-0517

●LT Series (Total Rubber Thickness 25cm)

Characteristics		LT160G4															
		T	S	F	E	D	C	B	A	G	H	I	J	K	L	M	
Physical Dimensions	Outer diameter (mm)	1600															
	Lead plug diameter (mm)	250	260	270	280	290	300	310	320	330	340	350	360	370	380	390	
	Effective plane area ($\times 10^2 \text{ mm}^2$)	19615	19575	19534	19490	19446	19399	19351	19302	19251	19198	19144	19088	19031	18972	18912	
	Thickness of one rubber layer (mm)	10.4															
	Number of rubber layers (-)	24															
	Total rubber thickness (mm)	250															
	First shape factor (-)	38.5															
	Second shape factor (-)	6.41															
	Diameter of flange (mm)	2000															
	Thickness of flange (edge/center) (mm)	50/110															
	Connecting bolt PCD (mm)	1800															
	Diameter of connecting bolt hole \times qty (mm)	$\varnothing 45 \times 12$															
	Bolt size (assumption) (-)	M42															
	Thickness of each reinforced steel plate (mm)	5.8															
	Total height (mm)	603.0															
Total weight (tonf)	7.40	7.41	7.43	7.44	7.46	7.47	7.49	7.51	7.52	7.54	7.56	7.58	7.60	7.62	7.64		
Total weight (kN)	72.5	72.7	72.8	73.0	73.1	73.3	73.4	73.6	73.8	73.9	74.1	74.3	74.5	74.7	74.9		
Compression Properties	Critical stress (N/mm^2) σ_{cr} when $\gamma = 0$	106															
	Ultimate compressive stress (N/mm^2)	(γ'_0, σ_0)	(0.00,60)														
		(γ'_1, σ_1)	(3.07,60)														
		(γ'_2, σ_2)	(4.00,46)														
	Compressive stiffness ($\times 10^3 \text{ kN}/\text{m}$)	9610															
	Nominal long term compressive stress (N/mm^2)	15.0															
	Nominal long term column load (kN)	29400	29400	29300	29200	29200	29100	29000	29000	28900	28800	28700	28600	28500	28500	28400	
Allowable tensile stress ($\gamma = 100\%$) (N/mm^2)	1.0																
Shear Properties ($\gamma = 100\%$)	Initial stiffness ($\times 10^3 \text{ kN}/\text{m}$)	40.8	40.9	40.9	41.0	41.0	41.0	41.1	41.1	41.2	41.3	41.3	41.4	41.4	41.5	41.5	
	Post yield stiffness ($\gamma = 100\%$) ($\times 10^3 \text{ kN}/\text{m}$)	3.14	3.14	3.15	3.15	3.15	3.16	3.16	3.17	3.17	3.17	3.18	3.18	3.19	3.19	3.20	
	Characteristic Strength (kN)	391	423	456	491	526	563	601	641	681	723	767	811	857	904	952	
	Equivalent shear stiffness ($\times 10^3 \text{ kN}/\text{m}$)	4.71	4.84	4.97	5.12	5.26	5.41	5.57	5.73	5.90	6.07	6.25	6.43	6.62	6.81	7.01	
	Equivalent damping ratio (-)	0.203	0.213	0.223	0.232	0.241	0.250	0.258	0.266	0.273	0.281	0.288	0.294	0.300	0.306	0.312	

Certification number MVBR-0517

Code

Compound name	Rubber code	Shear modulus [N/mm ²]
G4	G0.40	0.385

●LD Series (Total Rubber Thickness 32cm)

Characteristics		LD160G4															
		T	S	F	E	D	C	B	A	G	H	I	J	K	L	M	
Physical Dimensions	Outer diameter (mm)	1600															
	Lead plug diameter (mm)	250	260	270	280	290	300	310	320	330	340	350	360	370	380	390	
	Effective plane area (×10 ² mm ²)	19615	19575	19534	19490	19446	19399	19351	19302	19251	19198	19144	19088	19031	18972	18912	
	Thickness of one rubber layer (mm)	10.4															
	Number of rubber layers (-)	31															
	Total rubber thickness (mm)	322															
	First shape factor (-)	38.5															
	Second shape factor (-)	4.96															
	Diameter of flange (mm)	2000															
	Thickness of flange (edge/center) (mm)	50/100															
	Connecting bolt PCD (mm)	1800															
	Diameter of connecting bolt hole × qty (mm)	∅45 × 12															
	Bolt size (assumption) (-)	M42															
	Thickness of each reinforced steel plate (mm)	5.8															
	Total height (mm)	696.4															
Total weight (tonf)	7.91	7.93	7.95	7.96	7.98	8.00	8.02	8.04	8.07	8.09	8.11	8.13	8.16	8.18	8.21		
Total weight (kN)	77.6	77.7	77.9	78.1	78.3	78.5	78.7	78.9	79.1	79.3	79.5	79.8	80.0	80.3	80.5		
Compression Properties	Critical stress [N/mm ²] σ_{cr} when $\gamma = 0$	81															
	Ultimate compressive stress [N/mm ²]	(γ'_0, σ_0)	(0.00,60)														
		(γ'_1, σ_1)	(1.43,60)														
		(γ'_2, σ_2)	(4.00,22)														
	Compressive stiffness (×10 ³ kN/m)	7440															
	Nominal long term compressive stress [N/mm ²]	15.0															
	Nominal long term column load (kN)	29400	29400	29300	29200	29200	29100	29000	29000	28900	28800	28700	28600	28500	28500	28400	
Shear Properties ($\gamma = 100\%$)	Allowable tensile stress ($\gamma = 100\%$) [N/mm ²]	1.0															
	Initial stiffness (×10 ³ kN/m)	31.6	31.6	31.7	31.7	31.7	31.8	31.8	31.9	31.9	31.9	32.0	32.0	32.1	32.1	32.2	
	Post yield stiffness ($\gamma = 100\%$) (×10 ³ kN/m)	2.43	2.43	2.44	2.44	2.44	2.44	2.45	2.45	2.45	2.46	2.46	2.46	2.47	2.47	2.47	
	Characteristic Strength (kN)	391	423	456	491	526	563	601	641	681	723	767	811	857	904	952	
	Equivalent shear stiffness (×10 ³ kN/m)	3.64	3.75	3.85	3.96	4.07	4.19	4.31	4.44	4.57	4.70	4.84	4.98	5.12	5.27	5.43	
Equivalent damping ratio (-)	0.203	0.213	0.223	0.232	0.241	0.250	0.258	0.266	0.273	0.281	0.288	0.294	0.300	0.306	0.312		

Certification number MVBR-0517

●LD Series (Total Rubber Thickness 32cm)

Characteristics		LD170G4													
		S	F	E	D	C	B	A	G	H	I	J	K	L	
Physical Dimensions	Outer diameter (mm)	1700													
	Lead plug diameter*1 (mm)	280	290	300	310	320	330	340	350	360	370	380	390	200 × 4	
	Effective plane area (×10 ² mm ²)	22082	22037	21991	21943	21894	21843	21790	21736	21680	21623	21564	21503	21441	
	Thickness of one rubber layer (mm)	10.4													
	Number of rubber layers (-)	31													
	Total rubber thickness (mm)	322													
	First shape factor (-)	40.9													
	Second shape factor (-)	5.27													
	Diameter of flange (mm)	□ 1980													
	Thickness of flange (edge/center) (mm)	50/100													
	Connecting bolt PCD (mm)	-													
	Diameter of connecting bolt hole × qty (mm)	∅ 45 × 24													
	Bolt size (assumption) (-)	M42													
	Thickness of each reinforced steel plate (mm)	5.8													
	Total height (mm)	696.4													
Total weight (tonf)	9.30	9.32	9.34	9.36	9.38	9.40	9.42	9.45	9.47	9.49	9.52	9.54	9.57		
Total weight (kN)	91.2	91.4	91.6	91.8	92.0	92.2	92.4	92.6	92.9	93.1	93.3	93.6	93.9		
Compression Properties	Critical stress (N/mm ²)	σ_{cr} when $\gamma = 0$													
	Ultimate compressive stress (N/mm ²)	89													
		(γ_0, σ_0)	(0.00,60)												
		(γ_1, σ_1)	(1.90,60)												
	Compressive stiffness (×10 ³ kN/m)	(γ_2, σ_2)													
		(4.00,28)													
	Nominal long term compressive stress*2 (N/mm ²)	8570													
Nominal long term column load (kN)	15.0														
Allowable tensile stress ($\gamma = 100\%$) (N/mm ²)	33100	33100	33000	32900	32800	32800	32700	32600	32500	32400	32300	32300	32200		
Shear Properties ($\gamma = 100\%$)	Initial stiffness (×10 ³ kN/m)	1.0													
	Post yield stiffness ($\gamma = 100\%$) (×10 ³ kN/m)	35.7	35.8	35.8	35.8	35.9	35.9	36.0	36.0	36.0	36.1	36.1	36.2	36.2	
	Characteristic Strength (kN)	2.75	2.75	2.75	2.76	2.76	2.76	2.77	2.77	2.77	2.78	2.78	2.78	2.79	
	Equivalent shear stiffness (×10 ³ kN/m)	491	526	563	601	641	681	723	767	811	857	904	952	1000	
	Equivalent damping ratio (-)	4.27	4.38	4.50	4.62	4.75	4.88	5.01	5.15	5.29	5.43	5.58	5.74	5.89	
Equivalent damping ratio (-)	0.216	0.225	0.234	0.242	0.251	0.258	0.266	0.273	0.280	0.286	0.293	0.299	0.304		

*1 It will be a multi-plug structure if lead plug diameter is bigger than 390mm.

Certification number MVBR-0517

●LD Series (Total Rubber Thickness 32cm)

Characteristics		LD180G4													
		S	F	E	D	C	B	A	G	H	I	J	K	L	M
Physical Dimensions	Outer diameter (mm)	1800													
	Lead plug diameter*1 (mm)	300	310	320	330	340	350	360	370	380	390	200 × 4	205 × 4	210 × 4	215 × 4
	Effective plane area (×10 ² mm ²)	24740	24692	24643	24592	24539	24485	24429	24372	24313	24252	24190	24127	24061	23995
	Thickness of one rubber layer (mm)	11.1													
	Number of rubber layers (-)	29													
	Total rubber thickness (mm)	322													
	First shape factor (-)	40.5													
	Second shape factor (-)	5.59													
	Diameter of flange (mm)	□ 2080													
	Thickness of flange (edge/center) (mm)	50/100													
	Connecting bolt PCD (mm)	-													
	Diameter of connecting bolt hole × qty (mm)	∅ 45 × 24													
	Bolt size (assumption) (-)	M42													
	Thickness of each reinforced steel plate (mm)	5.8													
	Total height (mm)	684.3													
Total weight (tonf)	10.1	10.1	10.2	10.2	10.2	10.2	10.3	10.3	10.3	10.3	10.4	10.4	10.4	10.4	
Total weight (kN)	99.3	99.5	99.7	99.9	100.1	100.3	100.6	100.8	101.1	101.3	101.6	101.8	102.1	102.4	
Compression Properties	Critical stress (N/mm ²)	σ_{cr} when $\gamma = 0$		94											
	Ultimate compressive stress (N/mm ²)	(γ_0', σ_0)		(0.00,60)											
		(γ_1', σ_1)		(2.24,60)											
		(γ_2', σ_2)		(4.00,33)											
	Compressive stiffness (×10 ³ kN/m)	9600													
	Nominal long term compressive stress*2 (N/mm ²)	15.0													
	Nominal long term column load (kN)	37100	37000	37000	36900	36800	36700	36600	36600	36500	36400	36300	36200	36100	36000
Allowable tensile stress ($\gamma = 100\%$) (N/mm ²)	1.0														
Shear Properties ($\gamma = 100\%$)	Initial stiffness (×10 ³ kN/m)	40.1	40.2	40.2	40.2	40.3	40.3	40.4	40.4	40.5	40.5	40.6	40.6	40.7	40.7
	Post yield stiffness ($\gamma = 100\%$) (×10 ³ kN/m)	3.09	3.09	3.09	3.10	3.10	3.10	3.11	3.11	3.11	3.12	3.12	3.12	3.13	3.13
	Characteristic Strength (kN)	563	601	641	681	723	767	811	857	904	952	1000	1050	1100	1160
	Equivalent shear stiffness (×10 ³ kN/m)	4.84	4.96	5.08	5.21	5.35	5.48	5.63	5.77	5.92	6.07	6.23	6.39	6.56	6.73
	Equivalent damping ratio (-)	0.219	0.228	0.236	0.244	0.251	0.259	0.266	0.273	0.279	0.285	0.291	0.297	0.302	0.308

*1 It will be a multi-plug structure if lead plug diameter is bigger than 390mm.

Specification of flange (edge thickness / center thickness)

Outer diameter of rubber bearing (∅) ^{*1}	(600)	(650)	700	750	800	850	900	950	1000	1100	1200	1300
Standard thickness	22/28	22/28	22/28	22/28	24/32	24/32	28/36	28/36	28/36	30/38	32/40	32/40
Special thickness (option)	(26/32)	(26/32)	26/32	30/36	32/40	32/40	37/45	37/45	42/50	42/50	42/50	42/50

*1 For adoption of special thickness in regard to those sizes that stated in the (), delivery time will be longer due to mold preparation.

*2 For ∅1400 and above, assembled type flange will be used.

*3 Compared to the standard specification, total height & weight of product for special thickness will be changed.

Certification number MVBR-0517

Code

Compound name	Rubber code	Shear modulus [N/mm ²]
G4	60.40	0.385

●LS Series (S₂ = 5)

Characteristics		LS060G4										LS065G4									
		E	D	C	B	A	G	H	I	J	E	D	C	B	A	G	H	I	J		
Physical Dimensions	Outer diameter (mm)	600										650									
	Lead plug diameter (mm)	80	90	100	110	120	130	140	150	160	90	100	110	120	130	140	150	160	170		
	Effective plane area (×10 ² mm ²)	2777	2764	2749	2732	2714	2695	2673	2651	2626	3255	3240	3223	3205	3186	3164	3142	3117	3091		
	Thickness of one rubber layer (mm)	4.0										4.4									
	Number of rubber layers (-)	30										30									
	Total rubber thickness (mm)	120										132									
	First shape factor (-)	37.5										36.9									
	Second shape factor (-)	5.00										4.92									
	Diameter of flange (mm)	900										950									
	Thickness of flange* (edge/center) (mm)	22/28										22/28									
	Connecting bolt PCD (mm)	775										825									
	Diameter of connecting bolt hole × qty (mm)	∅ 33 × 12										∅ 33 × 12									
	Bolt size (assumption) (-)	M30										M30									
	Thickness of each reinforced steel plate (mm)	3.1										3.1									
	Total height (mm)	265.9										277.9									
Total weight (tonf)	0.50	0.50	0.51	0.51	0.51	0.52	0.52	0.52	0.53	0.58	0.58	0.59	0.59	0.59	0.60	0.60	0.61	0.61			
Total weight (kN)	4.9	4.9	5.0	5.0	5.0	5.1	5.1	5.1	5.2	5.7	5.7	5.8	5.8	5.8	5.9	5.9	6.0	6.0			
Compression Properties	Critical stress [N/mm ²]	81										78									
	Ultimate compressive stress [N/mm ²]	[γ ₀ , σ ₀]										[0.00,60]									
		[γ ₁ , σ ₁]										[1.46,60]									
		[γ ₂ , σ ₂]										[4.00,21]									
	Compressive stiffness (×10 ³ kN/m)	2790										2960									
	Nominal long term compressive stress [N/mm ²]	15.0										15.0									
	Nominal long term column load (kN)	4170	4150	4120	4100	4070	4040	4010	3980	3940	4880	4860	4830	4810	4780	4750	4710	4680	4640		
Allowable tensile stress (γ = 100%) [N/mm ²]	1.0										1.0										
Shear Properties (γ = 100%)	Initial stiffness (×10 ³ kN/m)	11.9	11.9	12.0	12.0	12.0	12.1	12.1	12.2	12.2	12.7	12.7	12.8	12.8	12.8	12.9	12.9	13.0	13.0		
	Post yield stiffness (γ = 100%) (×10 ³ kN/m)	0.915	0.918	0.920	0.923	0.926	0.929	0.933	0.936	0.940	0.977	0.980	0.982	0.985	0.988	0.991	0.994	0.998	1.00		
	Characteristic Strength (kN)	40.0	50.7	62.6	75.7	90.1	106	123	141	160	50.7	62.6	75.7	90.1	106	123	141	160	181		
	Equivalent shear stiffness (×10 ³ kN/m)	1.25	1.34	1.44	1.55	1.68	1.81	1.95	2.11	2.28	1.36	1.45	1.56	1.67	1.79	1.92	2.06	2.21	2.37		
	Equivalent damping ratio (-)	0.165	0.193	0.219	0.244	0.266	0.285	0.302	0.317	0.329	0.174	0.199	0.223	0.246	0.266	0.284	0.300	0.314	0.326		

* : Special thickness for flange is available. Please refer to the table above for more details.

Certification number MVBR-0517

●LS Series (S₂ = 5)

Characteristics		LS070G4										LS075G4											
		E	D	C	B	A	G	H	I	J	E	D	C	B	A	G	H	I	J				
Physical Dimensions	Outer diameter (mm)	700										750											
	Lead plug diameter (mm)	100	110	120	130	140	150	160	170	180	110	120	130	140	150	160	170	180	190				
	Effective plane area (×10 ² mm ²)	3770	3753	3735	3716	3695	3672	3647	3621	3594	4323	4305	4285	4264	4241	4217	4191	4163	4134				
	Thickness of one rubber layer (mm)	4.7										5.0											
	Number of rubber layers	30										30											
	Total rubber thickness (mm)	141										150											
	First shape factor	372										375											
	Second shape factor	4.96										5.00											
	Diameter of flange (mm)	1000										1100											
	Thickness of flange* (edge/center) (mm)	22/28										22/28											
	Connecting bolt PCD (mm)	875										950											
	Diameter of connecting bolt hole × qty	∅ 33 × 12										∅ 33 × 12											
	Bolt size (assumption)	M30										M30											
	Thickness of each reinforced steel plate (mm)	3.1										3.1											
	Total height (mm)	286.9										295.9											
Total weight (tonf)	0.67	0.67	0.67	0.68	0.68	0.69	0.69	0.70	0.70	0.79	0.79	0.80	0.80	0.81	0.81	0.82	0.82	0.83					
Total weight (kN)	6.5	6.6	6.6	6.7	6.7	6.7	6.8	6.8	6.9	7.7	7.8	7.8	7.9	7.9	8.0	8.0	8.1	8.1					
Compression Properties	Critical stress (N/mm ²)	σ_{cr} when $\gamma = 0$		80										81									
	Ultimate compressive stress (N/mm ²)	(γ_0, σ_0)		(0.00,60)										(0.00,60)									
		(γ_1, σ_1)		(1.38,60)										(1.46,60)									
		(γ_2, σ_2)		(4.00,22)										(4.00,23)									
	Compressive stiffness (×10 ³ kN/m)	3220										3480											
	Nominal long term compressive stress (N/mm ²)	15.0										15.0											
	Nominal long term column load (kN)	5650	5630	5600	5570	5540	5510	5470	5430	5390	6480	6460	6430	6400	6360	6330	6290	6250	6200				
Allowable tensile stress ($\gamma = 100\%$) (N/mm ²)	1.0										1.0												
Shear Properties ($\gamma = 100\%$)	Initial stiffness (×10 ³ kN/m)	13.8	13.8	13.9	13.9	13.9	14.0	14.0	14.1	14.1	14.9	14.9	15.0	15.0	15.0	15.1	15.1	15.2	15.2				
	Post yield stiffness ($\gamma = 100\%$) (×10 ³ kN/m)	1.06	1.06	1.07	1.07	1.07	1.08	1.08	1.08	1.09	1.15	1.15	1.15	1.15	1.16	1.16	1.16	1.17	1.17				
	Characteristic Strength (kN)	62.6	75.7	90.1	106	123	141	160	181	203	75.7	90.1	106	123	141	160	181	203	226				
	Equivalent shear stiffness (×10 ³ kN/m)	1.51	1.60	1.71	1.82	1.94	2.07	2.22	2.37	2.52	1.65	1.75	1.86	1.97	2.10	2.23	2.37	2.52	2.68				
	Equivalent damping ratio	0.181	0.205	0.227	0.247	0.266	0.283	0.298	0.311	0.323	0.187	0.209	0.229	0.248	0.266	0.282	0.296	0.309	0.320				

* : Special thickness for flange is available. Please refer to the table on the next page [upper top table] for more details.

Specification of flange (edge thickness / center thickness)

Outer diameter of rubber bearing (∅) ^{*1}	(600)	(650)	700	750	800	850	900	950	1000	1100	1200	1300
Standard thickness	22/28	22/28	22/28	22/28	24/32	24/32	28/36	28/36	28/36	30/38	32/40	32/40
Special thickness (option)	(26/32)	(26/32)	26/32	30/36	32/40	32/40	37/45	37/45	42/50	42/50	42/50	42/50

*1 For adoption of special thickness in regard to those sizes that stated in the (), delivery time will be longer due to mold preparation.

*2 For ∅1400 and above, assembled type flange will be used.

*3 Compared to the standard specification, total height & weight of product for special thickness will be changed.

Certification number MVBR-0517

●LS Series (S₂ = 5)

Characteristics		LS080G4										LS085G4											
		E	D	C	B	A	G	H	I	J	F	E	D	C	B	A	G	H	I	J	K		
Physical Dimensions	Outer diameter (mm)	800										850											
	Lead plug diameter (mm)	120	130	140	150	160	170	180	190	200	120	130	140	150	160	170	180	190	200	210	220		
	Effective plane area (×10 ² mm ²)	4913	4894	4873	4850	4825	4800	4772	4743	4712	5561	5542	5521	5498	5473	5448	5420	5391	5360	5328	5294		
	Thickness of one rubber layer (mm)	5.4										5.7											
	Number of rubber layers (-)	30										30											
	Total rubber thickness (mm)	162										171											
	First shape factor (-)	37.0										37.3											
	Second shape factor (-)	4.94										4.97											
	Diameter of flange (mm)	1150										1200											
	Thickness of flange* (edge/center) (mm)	24/32										24/32											
	Connecting bolt PCD (mm)	1000										1050											
	Diameter of connecting bolt hole × qty (mm)	∅33 × 12										∅33 × 12											
	Bolt size (assumption) (-)	M30										M30											
	Thickness of each reinforced steel plate (mm)	4.4										4.4											
	Total height (mm)	353.6										362.6											
Total weight (tonf)	1.09	1.10	1.10	1.11	1.11	1.12	1.13	1.13	1.14	1.22	1.23	1.23	1.24	1.24	1.25	1.26	1.26	1.27	1.28	1.29			
Total weight (kN)	10.7	10.8	10.8	10.9	10.9	11.0	11.1	11.1	11.2	12.0	12.0	12.1	12.1	12.2	12.3	12.3	12.4	12.5	12.5	12.6			
Compression Properties	Critical stress (N/mm ²)	σ_{cr} when $\gamma = 0$		79										80									
	Ultimate compressive stress (N/mm ²)	(γ'_0, σ_0)		(0.00,60)										(0.00,60)									
		(γ'_1, σ_1)		(1.31,60)										(1.39,60)									
		(γ'_2, σ_2)		(4.00,21)										(4.00,22)									
	Compressive stiffness (×10 ³ kN/m)			3650										3910									
	Nominal long term compressive stress (N/mm ²)			15.0										15.0									
	Nominal long term column load (kN)	7370	7340	7310	7270	7240	7200	7160	7110	7070	8340	8310	8280	8250	8210	8170	8130	8090	8040	7990	7940		
Allowable tensile stress ($\gamma = 100\%$) (N/mm ²)			1.0										1.0										
Shear Properties ($\gamma = 100\%$)	Initial stiffness (×10 ³ kN/m)	15.7	15.7	15.8	15.8	15.8	15.9	15.9	16.0	16.0	16.8	16.8	16.8	16.9	16.9	17.0	17.0	17.0	17.1	17.1	17.2		
	Post yield stiffness ($\gamma = 100\%$) (×10 ³ kN/m)	1.21	1.21	1.21	1.22	1.22	1.22	1.23	1.23	1.23	1.29	1.29	1.30	1.30	1.30	1.30	1.31	1.31	1.31	1.32	1.32		
	Characteristic Strength (kN)	90.1	106	123	141	160	181	203	226	250	90.1	106	123	141	160	181	203	226	250	276	303		
	Equivalent shear stiffness (×10 ³ kN/m)	1.76	1.86	1.97	2.09	2.21	2.34	2.48	2.62	2.78	1.82	1.91	2.01	2.12	2.24	2.36	2.49	2.63	2.78	2.93	3.09		
	Equivalent damping ratio (-)	0.193	0.213	0.232	0.250	0.266	0.281	0.294	0.306	0.317	0.178	0.198	0.216	0.234	0.251	0.266	0.280	0.293	0.304	0.315	0.324		

* : Special thickness for flange is available. Please refer to the table above for more details..

Certification number MVBR-0517

●LS Series ($S_2 = 5$)

Characteristics		LS090G4											LS095G4												
		F	E	D	C	B	A	G	H	I	J	K	F	E	D	C	B	A	G	H	I	J	K		
Physical Dimensions	Outer diameter (mm)	900											950												
	Lead plug diameter (mm)	130	140	150	160	170	180	190	200	210	220	230	140	150	160	170	180	190	200	210	220	230	240		
	Effective plane area ($\times 10^2 \text{ mm}^2$)	6229	6208	6185	6161	6135	6107	6078	6048	6015	5982	5946	6934	6912	6887	6861	6834	6805	6774	6742	6708	6673	6636		
	Thickness of one rubber layer (mm)	6.0											6.4												
	Number of rubber layers (-)	30											30												
	Total rubber thickness (mm)	180											192												
	First shape factor (-)	375											371												
	Second shape factor (-)	5.00											4.95												
	Diameter of flange (mm)	1250											1300												
	Thickness of flange* (edge/center) (mm)	28/36											28/36												
	Connecting bolt PCD (mm)	1100											1150												
	Diameter of connecting bolt hole \times qty (mm)	$\varnothing 33 \times 12$											$\varnothing 33 \times 12$												
	Bolt size (assumption) (-)	M30											M30												
	Thickness of each reinforced steel plate (mm)	4.4											4.4												
	Total height (mm)	379.6											391.6												
Total weight (tonf)	1.44	1.45	1.45	1.46	1.47	1.47	1.48	1.49	1.50	1.50	1.51	1.60	1.61	1.61	1.62	1.63	1.64	1.64	1.65	1.66	1.67	1.68			
Total weight (kN)	14.1	14.2	14.2	14.3	14.4	14.4	14.5	14.6	14.7	14.7	14.8	15.7	15.8	15.8	15.9	16.0	16.0	16.1	16.2	16.3	16.4	16.5			
Compression Properties	Critical stress (N/mm^2)	σ_{cr} when $\gamma = 0$		81											79										
	Ultimate compressive stress (N/mm^2)	(γ_0', σ_0)		(0.00,60)											(0.00,60)										
		(γ_1', σ_1)		(1.46,60)											(1.33,60)										
		(γ_2', σ_2)		(4.00,23)											(4.00,22)										
	Compressive stiffness ($\times 10^3 \text{ kN}/\text{m}$)	4180											4350												
	Nominal long term compressive stress (N/mm^2)	15.0											15.0												
	Nominal long term column load (kN)	9340	9310	9280	9240	9200	9160	9120	9070	9020	8970	8920	10400	10400	10300	10300	10300	10200	10200	10100	10100	10000	9950		
Allowable tensile stress ($\gamma = 100\%$) (N/mm^2)	1.0											1.0													
Shear Properties ($\gamma = 100\%$)	Initial stiffness ($\times 10^3 \text{ kN}/\text{m}$)	179	179	179	18.0	18.0	18.1	18.1	18.1	18.2	18.2	18.3	18.7	18.7	18.7	18.8	18.8	18.9	18.9	18.9	19.0	19.0	19.1		
	Post yield stiffness ($\gamma = 100\%$) ($\times 10^3 \text{ kN}/\text{m}$)	1.38	1.38	1.38	1.38	1.39	1.39	1.39	1.40	1.40	1.40	1.41	1.44	1.44	1.44	1.44	1.45	1.45	1.45	1.46	1.46	1.46	1.47		
	Characteristic Strength (kN)	106	123	141	160	181	203	226	250	276	303	331	123	141	160	181	203	226	250	276	303	331	360		
	Equivalent shear stiffness ($\times 10^3 \text{ kN}/\text{m}$)	1.96	2.06	2.16	2.27	2.39	2.52	2.65	2.79	2.93	3.09	3.25	2.08	2.17	2.28	2.39	2.50	2.63	2.76	2.89	3.04	3.19	3.35		
	Equivalent damping ratio (-)	0.184	0.202	0.219	0.236	0.251	0.266	0.279	0.291	0.302	0.312	0.321	0.189	0.206	0.222	0.238	0.252	0.266	0.278	0.290	0.301	0.310	0.319		

* : Special thickness for flange is available. Please refer to the table on the next page [upper top table] for more details.

Specification of flange (edge thickness / center thickness)

Outer diameter of rubber bearing (Ø) ^{*1}	(600)	(650)	700	750	800	850	900	950	1000	1100	1200	1300
Standard thickness	22/28	22/28	22/28	22/28	24/32	24/32	28/36	28/36	28/36	30/38	32/40	32/40
Special thickness (option)	(26/32)	(26/32)	26/32	30/36	32/40	32/40	37/45	37/45	42/50	42/50	42/50	42/50

*1 For adoption of special thickness in regard to those sizes that stated in the (), delivery time will be longer due to mold preparation.

*2 For Ø1400 and above, assembled type flange will be used.

*3 Compared to the standard specification, total height & weight of product for special thickness will be changed.

Certification number MVBR-0517

●LS Series (S₂ = 5)

Characteristics		LS100G4											LS110G4										
		F	E	D	C	B	A	G	H	I	J	K	F	E	D	C	B	A	G	H	I	J	K
Physical Dimensions	Outer diameter (mm)	1000											1100										
	Lead plug diameter (mm)	150	160	170	180	190	200	210	220	230	240	250	170	180	190	200	210	220	230	240	250	260	270
	Effective plane area (×10 ² mm ²)	7677	7653	7627	7600	7570	7540	7508	7474	7439	7402	7363	9276	9249	9220	9189	9157	9123	9088	9051	9012	8972	8931
	Thickness of one rubber layer (mm)	6.7											7.4										
	Number of rubber layers (-)	30											30										
	Total rubber thickness (mm)	201											222										
	First shape factor (-)	37.3											37.2										
	Second shape factor (-)	4.98											4.95										
	Diameter of flange (mm)	1400											1500										
	Thickness of flange* (edge/center) (mm)	28/36											30/38										
	Connecting bolt PCD (mm)	1250											1350										
	Diameter of connecting bolt hole × qty	Ø 39 × 12											Ø 39 × 12										
	Bolt size (assumption) (-)	M36											M36										
	Thickness of each reinforced steel plate (mm)	4.4											4.4										
	Total height (mm)	400.6											425.6										
Total weight (tonf)	1.82	1.82	1.83	1.84	1.85	1.86	1.86	1.87	1.88	1.89	1.90	2.24	2.25	2.26	2.27	2.28	2.29	2.30	2.31	2.32	2.33	2.35	
Total weight (kN)	17.8	17.9	18.0	18.0	18.1	18.2	18.3	18.4	18.5	18.6	18.7	22.0	22.1	22.2	22.3	22.3	22.4	22.5	22.7	22.8	22.9	23.0	
Compression Properties	Critical stress (N/mm ²)	80											80										
	Ultimate compressive stress (N/mm ²)	[γ ₀ , σ ₀]											[0.00,60]										
		[γ ₁ , σ ₁]											[1.40,60]										
		[γ ₂ , σ ₂]											[4.00,22]										
	Compressive stiffness (×10 ³ kN/m)	4610											5040										
	Nominal long term compressive stress (N/mm ²)	15.0											15.0										
	Nominal long term column load (kN)	11500	11500	11400	11400	11400	11300	11300	11200	11200	11100	11100	13900	13900	13800	13800	13700	13700	13600	13600	13500	13500	13400
Allowable tensile stress (γ = 100%) (N/mm ²)	1.0											1.0											
Shear Properties (γ = 100%)	Initial stiffness (×10 ³ kN/m)	19.8	19.8	19.8	19.9	19.9	20.0	20.0	20.0	20.1	20.1	20.2	21.7	21.7	21.8	21.8	21.8	21.9	21.9	21.9	22.0	22.0	22.1
	Post yield stiffness (γ = 100%) (×10 ³ kN/m)	1.52	1.52	1.53	1.53	1.53	1.54	1.54	1.54	1.55	1.55	1.55	1.67	1.67	1.67	1.68	1.68	1.68	1.69	1.69	1.70	1.70	1.70
	Characteristic Strength (kN)	141	160	181	203	226	250	276	303	331	360	391	181	203	226	250	276	303	331	360	391	423	456
	Equivalent shear stiffness (×10 ³ kN/m)	2.22	2.32	2.43	2.54	2.66	2.78	2.91	3.05	3.19	3.34	3.50	2.48	2.58	2.69	2.80	2.92	3.05	3.18	3.31	3.45	3.60	3.75
	Equivalent damping ratio (-)	0.193	0.209	0.224	0.239	0.253	0.266	0.278	0.289	0.299	0.309	0.317	0.200	0.215	0.229	0.242	0.254	0.266	0.277	0.287	0.297	0.305	0.313

*: Special thickness for flange is available. Please refer to the table above for more details..

Certification number MVBR-0517

●LS Series ($S_2 = 5$)

Characteristics		LS120G4													
		S	F	E	D	C	B	A	G	H	I	J	K	L	
Physical Dimensions	Outer diameter (mm)	1200													
	Lead plug diameter (mm)	180	190	200	210	220	230	240	250	260	270	280	290	300	
	Effective plane area ($\times 10^2 \text{ mm}^2$)	11055	11026	10996	10963	10930	10894	10857	10819	10779	10737	10694	10649	10603	
	Thickness of one rubber layer (mm)	8.0													
	Number of rubber layers (-)	30													
	Total rubber thickness (mm)	240													
	First shape factor (-)	37.5													
	Second shape factor (-)	5.00													
	Diameter of flange (mm)	1600													
	Thickness of flange* (edge/center) (mm)	32/40													
	Connecting bolt PCD (mm)	1450													
	Diameter of connecting bolt hole \times qty (mm)	$\varnothing 39 \times 12$													
	Bolt size (assumption) (-)	M36													
	Thickness of each reinforced steel plate (mm)	4.4													
	Total height (mm)	447.6													
Total weight (tonf)	2.71	2.72	2.73	2.74	2.75	2.76	2.77	2.79	2.80	2.81	2.83	2.84	2.85		
Total weight (kN)	26.6	26.7	26.8	26.9	27.0	27.1	27.2	27.3	27.4	27.6	27.7	27.9	28.0		
Compression Properties	Critical stress (N/mm^2) σ_{cr} when $\gamma = 0$	81													
	Ultimate compressive stress (N/mm^2)	(γ_0, σ_0)	(0.00,60)												
		(γ_1, σ_1)	(1.46,60)												
		(γ_2, σ_2)	(4.00,23)												
	Compressive stiffness ($\times 10^3 \text{ kN}/\text{m}$)	5570													
	Nominal long term compressive stress (N/mm^2)	15.0													
	Nominal long term column load (kN)	16500	16500	16500	16400	16400	16300	16300	16200	16200	16100	16000	16000	15900	
Allowable tensile stress ($\gamma = 100\%$) (N/mm^2)	1.0														
Shear Properties ($\gamma = 100\%$)	Initial stiffness ($\times 10^3 \text{ kN}/\text{m}$)	23.9	23.9	23.9	24.0	24.0	24.0	24.1	24.1	24.2	24.2	24.2	24.3	24.3	
	Post yield stiffness ($\gamma = 100\%$) ($\times 10^3 \text{ kN}/\text{m}$)	1.84	1.84	1.84	1.84	1.85	1.85	1.85	1.85	1.86	1.86	1.87	1.87	1.87	
	Characteristic Strength (kN)	203	226	250	276	303	331	360	391	423	456	491	526	563	
	Equivalent shear stiffness ($\times 10^3 \text{ kN}/\text{m}$)	2.68	2.78	2.88	2.99	3.11	3.23	3.35	3.48	3.62	3.76	3.91	4.06	4.22	
	Equivalent damping ratio (-)	0.193	0.206	0.219	0.232	0.244	0.255	0.266	0.276	0.285	0.294	0.302	0.310	0.317	

* : Special thickness for flange is available. Please refer to the table above for more details.

Specification of flange (edge thickness / center thickness)

Outer diameter of rubber bearing (Ø) ^{*1}	(600)	(650)	700	750	800	850	900	950	1000	1100	1200	1300
Standard thickness	22/28	22/28	22/28	22/28	24/32	24/32	28/36	28/36	28/36	30/38	32/40	32/40
Special thickness (option)	(26/32)	(26/32)	26/32	30/36	32/40	32/40	37/45	37/45	42/50	42/50	42/50	42/50

*1 For adoption of special thickness in regard to those sizes that stated in the (), delivery time will be longer due to mold preparation.

*2 For Ø1400 and above, assembled type flange will be used.

*3 Compared to the standard specification, total height & weight of product for special thickness will be changed.

Certification number MVBR-0517

●LS Series (S₂ = 5)

Characteristics		LS130G4												
		S	F	E	D	C	B	A	G	H	I	J	K	L
Physical Dimensions	Outer diameter (mm)	1300												
	Lead plug diameter (mm)	200	210	220	230	240	250	260	270	280	290	300	310	320
	Effective plane area (×10 ² mm ²)	12959	12927	12893	12858	12821	12782	12742	12701	12657	12613	12566	12518	12469
	Thickness of one rubber layer (mm)	8.7												
	Number of rubber layers (-)	30												
	Total rubber thickness (mm)	261												
	First shape factor (-)	37.4												
	Second shape factor (-)	4.98												
	Diameter of flange (mm)	1700												
	Thickness of flange* (edge/center) (mm)	32/40												
	Connecting bolt PCD (mm)	1550												
	Diameter of connecting bolt hole × qty (mm)	Ø39 × 12												
	Bolt size (assumption) (-)	M36												
	Thickness of each reinforced steel plate (mm)	4.4												
	Total height (mm)	468.6												
Total weight (tonf)	3.18	3.19	3.20	3.21	3.23	3.24	3.25	3.27	3.28	3.30	3.31	3.33	3.35	
Total weight (kN)	31.2	31.3	31.4	31.5	31.6	31.8	31.9	32.0	32.2	32.3	32.5	32.6	32.8	
Compression Properties	Critical stress (N/mm ²)	81												
	Ultimate compressive stress (N/mm ²)	[γ ₀ , σ ₀]												
		[γ ₁ , σ ₁]												
		[γ ₂ , σ ₂]												
	Compressive stiffness (×10 ³ kN/m)	6000												
	Nominal long term compressive stress (N/mm ²)	15.0												
	Nominal long term column load (kN)	19400	19400	19300	19300	19200	19200	19100	19100	19000	18900	18800	18800	18700
Shear Properties (γ = 100%)	Allowable tensile stress (γ = 100%) (N/mm ²)	1.0												
	Initial stiffness (×10 ³ kN/m)	25.8	25.8	25.8	25.9	25.9	25.9	26.0	26.0	26.1	26.1	26.2	26.2	26.2
	Post yield stiffness (γ = 100%) (×10 ³ kN/m)	1.98	1.98	1.99	1.99	1.99	2.00	2.00	2.00	2.00	2.01	2.01	2.02	2.02
	Characteristic Strength (kN)	250	276	303	331	360	391	423	456	491	526	563	601	641
	Equivalent shear stiffness (×10 ³ kN/m)	2.94	3.04	3.15	3.26	3.37	3.49	3.62	3.75	3.88	4.02	4.17	4.32	4.47
Equivalent damping ratio (-)	0.199	0.211	0.223	0.235	0.246	0.256	0.266	0.275	0.284	0.292	0.300	0.307	0.314	

* : Special thickness for flange is available. Please refer to the table above for more details.

Certification number MVBR-0517

●LS Series (S₂ = 5)

Characteristics		LS140G4													
		T	S	F	E	D	C	B	A	G	H	I	J	K	L
Physical Dimensions	Outer diameter (mm)	1400													
	Lead plug diameter (mm)	210	220	230	240	250	260	270	280	290	300	310	320	330	340
	Effective plane area (×10 ² mm ²)	15047	15014	14978	14941	14903	14863	14821	14778	14733	14687	14639	14590	14539	14486
	Thickness of one rubber layer (mm)	9.3													
	Number of rubber layers (-)	30													
	Total rubber thickness (mm)	279													
	First shape factor (-)	376													
	Second shape factor (-)	5.02													
	Diameter of flange (mm)	1800													
	Thickness of flange (edge/center) (mm)	37/45													
	Connecting bolt PCD (mm)	1650													
	Diameter of connecting bolt hole × qty (mm)	∅42 × 12													
	Bolt size (assumption) (-)	M39													
	Thickness of each reinforced steel plate (mm)	5.8													
	Total height (mm)	537.2													
Total weight (tonf)	4.38	4.39	4.40	4.42	4.43	4.44	4.46	4.48	4.49	4.51	4.53	4.55	4.57	4.59	
Total weight (kN)	42.9	43.0	43.2	43.3	43.4	43.6	43.7	43.9	44.1	44.2	44.4	44.6	44.8	45.0	
Compression Properties	Critical stress (N/mm ²)	σ_{cr} when $\gamma = 0$	82												
	Ultimate compressive stress (N/mm ²)	(γ'_0, σ_0)	(0.00,60)												
		(γ'_1, σ_1)	(1.49,60)												
		(γ'_2, σ_2)	(4.00,23)												
	Compressive stiffness (×10 ³ kN/m)	6530													
	Nominal long term compressive stress (N/mm ²)	15.0													
	Nominal long term column load (kN)	22600	22500	22500	22400	22400	22300	22200	22200	22100	22000	22000	21900	21800	21700
Shear Properties ($\gamma = 100\%$)	Allowable tensile stress ($\gamma = 100\%$) (N/mm ²)	1.0													
	Initial stiffness (×10 ³ kN/m)	279	28.0	28.0	28.0	28.1	28.1	28.1	28.2	28.2	28.3	28.3	28.4	28.4	28.5
	Post yield stiffness ($\gamma = 100\%$) (×10 ³ kN/m)	2.15	2.15	2.15	2.16	2.16	2.16	2.16	2.17	2.17	2.17	2.18	2.18	2.18	2.19
	Characteristic Strength (kN)	276	303	331	360	391	423	456	491	526	563	601	641	681	723
	Equivalent shear stiffness (×10 ³ kN/m)	3.14	3.24	3.34	3.45	3.56	3.68	3.80	3.93	4.06	4.19	4.33	4.48	4.63	4.78
Equivalent damping ratio (-)	0.193	0.205	0.216	0.227	0.237	0.247	0.257	0.266	0.275	0.283	0.291	0.298	0.305	0.311	

Certification number MVBR-0517

●LS Series ($S_2 = 5$)

Characteristics		LU150G4														
		T	S	F	E	D	C	B	A	G	H	I	J	K	L	M
Physical Dimensions	Outer diameter (mm)	1500														
	Lead plug diameter (mm)	230	240	250	260	270	280	290	300	310	320	330	340	350	360	370
	Effective plane area ($\times 10^2 \text{ mm}^2$)	17256	17219	17181	17141	17099	17056	17011	16965	16917	16867	16816	16764	16709	16654	16596
	Thickness of one rubber layer (mm)	8.5														
	Number of rubber layers (-)	35														
	Total rubber thickness (mm)	298														
	First shape factor (-)	44.1														
	Second shape factor (-)	5.04														
	Diameter of flange (mm)	1900														
	Thickness of flange (edge/center) (mm)	50/100														
	Connecting bolt PCD (mm)	1750														
	Diameter of connecting bolt hole \times qty (mm)	$\varnothing 42 \times 16$														
	Bolt size (assumption) (-)	M39														
	Thickness of each reinforced steel plate (mm)	5.8														
	Total height (mm)	694.7														
Total weight (tonf)	7.22	7.24	7.26	7.27	7.29	7.31	7.32	7.34	7.36	7.38	7.40	7.43	7.45	7.47	7.49	
Total weight (kN)	70.9	71.0	71.2	71.3	71.5	71.7	71.8	72.0	72.2	72.4	72.6	72.8	73.0	73.3	73.5	
Compression Properties	Critical stress (N/mm^2)	σ_{cr} when $\gamma = 0$		87												
	Ultimate compressive stress (N/mm^2)	(γ'_0, σ_0)		(0.00,60)												
		(γ'_1, σ_1)		(1.75,60)												
		(γ'_2, σ_2)		(4.00,25)												
	Compressive stiffness ($\times 10^3 \text{ kN}/\text{m}$)	7400														
	Nominal long term compressive stress (N/mm^2)	15.0														
	Nominal long term column load (kN)	25900	25800	25800	25700	25600	25600	25500	25400	25400	25300	25200	25100	25100	25000	24900
Shear Properties ($\gamma = 100\%$)	Allowable tensile stress ($\gamma = 100\%$) (N/mm^2)	1.0														
	Initial stiffness ($\times 10^3 \text{ kN}/\text{m}$)	30.1	30.1	30.2	30.2	30.2	30.3	30.3	30.3	30.4	30.4	30.5	30.5	30.6	30.6	30.7
	Post yield stiffness ($\gamma = 100\%$) ($\times 10^3 \text{ kN}/\text{m}$)	2.31	2.32	2.32	2.32	2.33	2.33	2.33	2.33	2.34	2.34	2.34	2.35	2.35	2.35	2.36
	Characteristic Strength (kN)	331	360	391	423	456	491	526	563	601	641	681	723	767	811	857
	Equivalent shear stiffness ($\times 10^3 \text{ kN}/\text{m}$)	3.43	3.53	3.63	3.74	3.86	3.98	4.10	4.23	4.36	4.49	4.63	4.78	4.93	5.08	5.24
Equivalent damping ratio (-)	0.198	0.209	0.219	0.229	0.239	0.248	0.257	0.266	0.274	0.282	0.289	0.296	0.302	0.309	0.314	

Description of the product designation

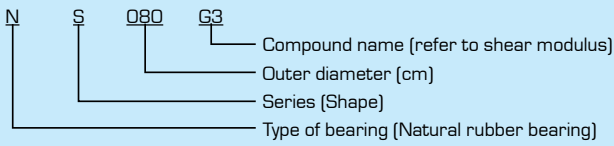

Natural Rubber Bearing (NRB)

Certification Number MVBR-0295 (N3,G3,G5)

Code

Compound name	Rubber code	Shear modulus [N/mm ²]
N3	G0.30	0.294

● NS Series (S₂ = 5)

Characteristics		NS060N3	NS065N3	NS070N3	NS075N3	NS080N3	NS085N3	NS090N3	NS095N3	NS100N3	NS110N3	NS120N3	
3D Physical Dimensions	Outer diameter (mm)	600	650	700	750	800	850	900	950	1000	1100	1200	
	Inner diameter (mm)	15	15	15	15	20	20	20	20	25	25	25	
	Effective plane area (×10 ² mm ²)	2826	3317	3847	4416	5023	5671	6359	7085	7849	9498	11305	
	Thickness of one rubber layer (mm)	4.0	4.4	4.7	5.0	5.4	5.7	6.0	6.4	6.7	7.4	8.0	
	Number of rubber layers (-)	30	30	30	30	30	30	30	30	30	30	30	
	Total rubber thickness (mm)	120	132	141	150	162	171	180	192	201	222	240	
	First shape factor (-)	36.6	36.1	36.4	36.8	36.1	36.4	36.7	36.3	36.4	36.3	36.7	
	Second shape factor (-)	5.00	4.92	4.96	5.00	4.94	4.97	5.00	4.95	4.98	4.95	5.00	
	Diameter of flange (mm)	900	950	1000	1100	1150	1200	1250	1300	1400	1500	1600	
	Thickness of flange* (edge/center) (mm)	22/28	22/28	22/28	22/28	24/32	24/32	28/36	28/36	28/36	30/38	32/40	
	Connecting bolt PCD (mm)	775	825	875	950	1000	1050	1100	1150	1250	1350	1450	
	Diameter of connecting bolt hole × qty (mm)	∅33 × 12	∅33 × 12	∅33 × 12	∅33 × 12	∅33 × 12	∅33 × 12	∅33 × 12	∅33 × 12	∅39 × 12	∅39 × 12	∅39 × 12	
	Bolt size (assumption) (-)	M30	M30	M30	M30	M30	M30	M30	M30	M36	M36	M36	
	Thickness of each reinforced steel plate (mm)	3.1	3.1	3.1	3.1	4.4	4.4	4.4	4.4	4.4	4.4	4.4	
	Total height (mm)	265.9	277.9	286.9	295.9	353.6	362.6	379.6	391.6	400.6	425.6	447.6	
Total weight (tonf)	0.49	0.57	0.65	0.77	1.07	1.19	1.41	1.56	1.77	2.17	2.63		
Total weight (kN)	4.8	5.6	6.4	7.5	10.5	11.7	13.8	15.3	17.3	21.3	25.8		
Compression Properties	Critical stress (N/mm ²)	σ_c when $\gamma = 0$	53	51	52	53	51	52	53	52	52	53	
	Ultimate compressive stress (N/mm ²)	(γ_0, σ_0)	(0.00,40)	(0.00,40)	(0.00,40)	(0.00,40)	(0.00,40)	(0.00,40)	(0.00,40)	(0.00,40)	(0.00,40)	(0.00,40)	
		(γ_1, σ_1)	(1.58,40)	(1.39,40)	(1.50,40)	(1.59,40)	(1.42,40)	(1.51,40)	(1.59,40)	(1.46,40)	(1.52,40)	(1.47,40)	(1.59,40)
		(γ_2, σ_2)	(4.00,21)	(4.00,19)	(4.00,20)	(4.00,21)	(4.00,19)	(4.00,20)	(4.00,20)	(4.00,20)	(4.00,20)	(4.00,20)	(4.00,20)
	Compressive stiffness (×10 ³ kN/m)		2140	2270	2470	2680	2800	3000	3210	3340	3540	3870	4290
	Nominal long term compressive stress (N/mm ²)		10.0	10.0	10.0	10.0	10.0	10.0	10.0	10.0	10.0	10.0	10.0
	Nominal long term column load (kN)		2830	3320	3850	4420	5020	5670	6360	7090	7850	9500	11300
Allowable tensile stress ($\gamma = 100\%$) (N/mm ²)		1.0	1.0	1.0	1.0	1.0	1.0	1.0	1.0	1.0	1.0	1.0	
Shear Properties	Shear stiffness (shear strain: $\gamma = \pm 100\%$) (×10 ³ kN/m)		0.693	0.739	0.803	0.866	0.912	0.976	1.04	1.09	1.15	1.26	1.39

* : Special thickness for flange is available. Please refer to the table on the next page (upper top table) for more details.

Specification of flange (edge thickness / center thickness)

Outer diameter of rubber bearing (∅) ^{*1}	(600)	(650)	700	750	800	850	900	950	1000	1100	1200	1300
Standard thickness	22/28	22/28	22/28	22/28	24/32	24/32	28/36	28/36	28/36	30/38	32/40	32/40
Special thickness (option)	(26/32)	(26/32)	26/32	30/36	32/40	32/40	37/45	37/45	42/50	42/50	42/50	42/50

*1 For adoption of special thickness in regard to those sizes that stated in the (), delivery time will be longer due to mold preparation.

*2 For ∅1400 and above, assembled type flange will be used.

*3 Compared to the standard specification, total height & weight of product for special thickness will be changed.

Certification number MVBR-0295 (N3,G3,G5)

Code

Compound name	Rubber code	Shear modulus [N/mm ²]
G3	G0.35	0.343

●NS Series (S₂ = 5)

Characteristics		NS060G3	NS065G3	NS070G3	NS075G3	NS080G3	NS085G3	NS090G3	NS095G3	NS100G3	NS110G3	NS120G3	
30Physical Dimensions	Outer diameter (mm)	600	650	700	750	800	850	900	950	1000	1100	1200	
	Inner diameter (mm)	15	15	15	15	20	20	20	20	25	25	25	
	Effective plane area (×10 ² mm ²)	2826	3317	3847	4416	5023	5671	6359	7085	7849	9498	11305	
	Thickness of one rubber layer (mm)	4.0	4.4	4.7	5.0	5.4	5.7	6.0	6.4	6.7	7.4	8.0	
	Number of rubber layers (-)	30	30	30	30	30	30	30	30	30	30	30	
	Total rubber thickness (mm)	120	132	141	150	162	171	180	192	201	222	240	
	First shape factor (-)	36.6	36.1	36.4	36.8	36.1	36.4	36.7	36.3	36.4	36.3	36.7	
	Second shape factor (-)	5.00	4.92	4.96	5.00	4.94	4.97	5.00	4.95	4.98	4.95	5.00	
	Diameter of flange (mm)	900	950	1000	1100	1150	1200	1250	1300	1400	1500	1600	
	Thickness of flange* (edge/center) (mm)	22/28	22/28	22/28	22/28	24/32	24/32	28/36	28/36	28/36	30/38	32/40	
	Connecting bolt PCD (mm)	775	825	875	950	1000	1050	1100	1150	1250	1350	1450	
	Diameter of connecting bolt hole × qty (mm)	∅ 33 × 12	∅ 33 × 12	∅ 33 × 12	∅ 33 × 12	∅ 33 × 12	∅ 33 × 12	∅ 33 × 12	∅ 33 × 12	∅ 39 × 12	∅ 39 × 12	∅ 39 × 12	
	Bolt size (assumption) (-)	M30	M30	M30	M30	M30	M30	M30	M30	M36	M36	M36	
	Thickness of each reinforced steel plate (mm)	3.1	3.1	3.1	3.1	4.4	4.4	4.4	4.4	4.4	4.4	4.4	
	Total height (mm)	265.9	277.9	286.9	295.9	353.6	362.6	379.6	391.6	400.6	425.6	447.6	
Total weight (tonf)	0.49	0.57	0.65	0.77	1.07	1.19	1.41	1.56	1.77	2.17	2.63		
Total weight (kN)	4.8	5.6	6.4	7.5	10.5	11.7	13.8	15.3	17.3	21.3	25.8		
Compression Properties	Critical stress [N/mm ²]	σ_{cr} when $\gamma = 0$	59	57	58	59	58	58	59	58	58	59	
	Ultimate compressive stress [N/mm ²]	(γ_1, σ_1)	(0.00,40)	(0.00,40)	(0.00,40)	(0.00,40)	(0.00,40)	(0.00,40)	(0.00,40)	(0.00,40)	(0.00,40)	(0.00,40)	(0.00,40)
		(γ_1, σ_1)	(2.12,40)	(1.93,40)	(2.04,40)	(2.13,40)	(1.97,40)	(2.05,40)	(2.12,40)	(2.00,40)	(2.06,40)	(2.01,40)	(2.13,40)
		(γ_2, σ_2)	(4.00,23)	(4.00,22)	(4.00,22)	(4.00,23)	(4.00,22)	(4.00,23)	(4.00,23)	(4.00,22)	(4.00,23)	(4.00,22)	(4.00,23)
	Compressive stiffness (×10 ³ kN/m)		2220	2350	2560	2780	2900	3120	3330	3460	3670	4020	4440
	Nominal long term compressive stress [N/mm ²]		10.0	10.0	10.0	10.0	10.0	10.0	10.0	10.0	10.0	10.0	10.0
	Nominal long term column load (kN)		2830	3320	3850	4420	5020	5670	6360	7090	7850	9500	11300
Allowable tensile stress ($\gamma = 100\%$) [N/mm ²]		1.0	1.0	1.0	1.0	1.0	1.0	1.0	1.0	1.0	1.0	1.0	
Shear Properties	Shear stiffness (shear strain: $\gamma = \pm 100\%$) (×10 ³ kN/m)		0.808	0.862	0.936	1.01	1.06	1.14	1.21	1.27	1.34	1.47	1.62

* : Special thickness for flange is available. Please refer to the table above for more details.

Certification number MVBR-0295 (N3,G3,G5)

Code

Compound name	Rubber code	Shear modulus [N/mm ²]
G5	G0.45	0.441

●NS Series (S₂ = 5)

Characteristics		NS060G5	NS065G5	NS070G5	NS075G5	NS080G5	NS085G5	NS090G5	NS095G5	NS100G5	NS110G5	NS120G5	NS130G5	NS140G5	NU150G5	
3D Physical Dimensions	Outer diameter (mm)	600	650	700	750	800	850	900	950	1000	1100	1200	1300	1400	1500	
	Inner diameter (mm)	15	15	15	15	20	20	20	20	25	25	25	30	30	40	
	Effective plane area (×10 ² mm ²)	2826	3317	3847	4416	5023	5671	6359	7085	7849	9498	11305	13266	15387	17659	
	Thickness of one rubber layer (mm)	4.0	4.4	4.7	5.0	5.4	5.7	6.0	6.4	6.7	7.4	8.0	8.7	9.3	8.5	
	Number of rubber layers (-)	30	30	30	30	30	30	30	30	30	30	30	30	30	35	
	Total rubber thickness (mm)	120	132	141	150	162	171	180	192	201	222	240	261	279	298	
	First shape factor (-)	36.6	36.1	36.4	36.8	36.1	36.4	36.7	36.3	36.4	36.3	36.7	36.5	36.8	42.9	
	Second shape factor (-)	5.00	4.92	4.96	5.00	4.94	4.97	5.00	4.95	4.98	4.95	5.00	4.98	5.02	5.04	
	Diameter of flange (mm)	900	950	1000	1100	1150	1200	1250	1300	1400	1500	1600	1700	1800	1900	
	Thickness of flange* (edge/center) (mm)	22/28	22/28	22/28	22/28	24/32	24/32	28/36	28/36	28/36	30/38	32/40	32/40	37/45	50/100	
	Connecting bolt PCD (mm)	775	825	875	950	1000	1050	1100	1150	1250	1350	1450	1550	1650	1750	
	Diameter of connecting bolt hole × qty (mm)	∅33 × 12	∅33 × 12	∅33 × 12	∅33 × 12	∅33 × 12	∅33 × 12	∅33 × 12	∅33 × 12	∅33 × 12	∅39 × 12	∅39 × 12	∅39 × 12	∅39 × 12	∅42 × 12	∅42 × 16
	Bolt size (assumption) (-)	M30	M30	M30	M30	M30	M30	M30	M30	M30	M36	M36	M36	M36	M39	M39
	Thickness of each reinforced steel plate (mm)	3.1	3.1	3.1	3.1	4.4	4.4	4.4	4.4	4.4	4.4	4.4	4.4	5.8	5.8	
	Total height (mm)	265.9	277.9	286.9	295.9	353.6	362.6	379.6	391.6	400.6	425.6	447.6	468.6	537.2	694.7	
Total weight (tonf)	0.49	0.57	0.65	0.77	1.07	1.19	1.41	1.56	1.77	2.17	2.63	3.07	4.24	7.05		
Total weight (kN)	4.8	5.6	6.4	7.5	10.5	11.7	13.8	15.3	17.3	21.3	25.8	30.1	41.6	69.2		
Compression Properties	Critical stress [N/mm ²]	σ_{cr} when $\gamma = 0$	72	70	71	72	71	71	72	71	72	71	72	73	77	
	Ultimate compressive stress [N/mm ²]	(γ_1, σ_1)	(0.00,60)	(0.00,60)	(0.00,60)	(0.00,60)	(0.00,60)	(0.00,60)	(0.00,60)	(0.00,60)	(0.00,60)	(0.00,60)	(0.00,60)	(0.00,60)	(0.00,60)	(0.00,60)
		(γ_1, σ_1)	(112,60)	(0.93,60)	(1.04,60)	(1.13,60)	(0.96,60)	(1.05,60)	(1.12,60)	(1.00,60)	(1.05,60)	(1.01,60)	(1.12,60)	(1.07,60)	(1.15,60)	(1.49,60)
		(γ_2, σ_2)	(4.00,28)	(4.00,26)	(4.00,27)	(4.00,28)	(4.00,27)	(4.00,28)	(4.00,28)	(4.00,27)	(4.00,28)	(4.00,27)	(4.00,28)	(4.00,28)	(4.00,29)	(4.00,31)
	Compressive stiffness (×10 ³ kN/m)		2490	2640	2880	3110	3260	3500	3730	3890	4110	4510	4980	5360	5840	6620
	Nominal long term compressive stress [N/mm ²]		15.0	15.0	15.0	15.0	15.0	15.0	15.0	15.0	15.0	15.0	15.0	15.0	15.0	15.0
	Nominal long term column load [kN]		4240	4970	5770	6620	7540	8510	9540	10600	11800	14200	17000	19900	23100	26500
Allowable tensile stress ($\gamma = 100\%$) [N/mm ²]		1.0	1.0	1.0	1.0	1.0	1.0	1.0	1.0	1.0	1.0	1.0	1.0	1.0	1.0	
Shear Properties	Shear stiffness (shear strain: $\gamma = \pm 100\%$) (×10 ³ kN/m)		1.04	1.11	1.20	1.30	1.37	1.46	1.56	1.63	1.72	1.89	2.08	2.24	2.43	2.62

* : Special thickness for flange is available. Please refer to the table on the next page (upper top table) for more details.

Specification of flange (edge thickness / center thickness)

Outer diameter of rubber bearing (Ø) ^{*1}	(600)	(650)	700	(750)	800	850	900	950	1000	1100	1200	1300
Standard thickness	22/28	22/28	22/28	22/28	24/32	24/32	28/36	28/36	28/36	30/38	32/40	32/40
Special thickness (option)	[26/32]	[26/32]	26/32	[30/36]	32/40	32/40	37/45	37/45	42/50	42/50	42/50	42/50

×1 For adoption of special thickness in regard to those sizes that stated in the (), delivery time will be longer due to mold preparation.
 ×2 For Ø1400 and above, assembled type flange will be used.
 ×3 Compared to the standard specification, total height & weight of product for special thickness will be changed.

Certification number MVBR-0509/MVBR-0518 (G4)

Note: There are 2 certification numbers due to difference of some manufacturing process.
 Please refer to "Precautions" in page 11 for the certificate number that used for design document.

Code

Compound name	Rubber code	Shear modulus [N/mm ²]
G4	60.40	0.392

●NS Series (S₂ = 5)

Characteristics		NS060G4	NS065G4	NS070G4	NS075G4	NS080G4	NS085G4	NS090G4	NS095G4	NS100G4	NS110G4	NS120G4	NS130G4	NS140G4	NU150G4	
30Physical Dimensions	Outer diameter (mm)	600	650	700	750	800	850	900	950	1000	1100	1200	1300	1400	1500	
	Inner diameter (mm)	15	15	15	15	20	20	20	20	25	55	55	55	65	65	
	Effective plane area (×10 ² mm ²)	2826	3317	3847	4416	5023	5671	6359	7085	7849	9480	11286	13249	15361	17638	
	Thickness of one rubber layer (mm)	4.0	4.4	4.7	5.0	5.4	5.7	6.0	6.4	6.7	7.4	8.0	8.7	9.3	8.5	
	Number of rubber layers (-)	30	30	30	30	30	30	30	30	30	30	30	30	30	35	
	Total rubber thickness (mm)	120	132	141	150	162	171	180	192	201	222	240	261	279	298	
	First shape factor (-)	36.6	36.1	36.4	36.8	36.1	36.4	36.7	36.3	36.4	35.3	35.8	35.8	35.9	42.2	
	Second shape factor (-)	5.00	4.92	4.96	5.00	4.94	4.97	5.00	4.95	4.98	4.95	5.00	4.98	5.02	5.04	
	Diameter of flange (mm)	900	950	1000	1100	1150	1200	1250	1300	1400	1500	1600	1700	1800	1900	
	Thickness of flange* (edge/center) (mm)	22/28	22/28	22/28	22/28	24/32	24/32	28/36	28/36	28/36	30/38	32/40	32/40	37/45	50/100	
	Connecting bolt PCD (mm)	775	825	875	950	1000	1050	1100	1150	1250	1350	1450	1550	1650	1750	
	Diameter of connecting bolt hole × qty (mm)	Ø33 × 12	Ø33 × 12	Ø33 × 12	Ø33 × 12	Ø33 × 12	Ø33 × 12	Ø33 × 12	Ø33 × 12	Ø33 × 12	Ø39 × 12	Ø39 × 12	Ø39 × 12	Ø39 × 12	Ø42 × 12	Ø42 × 16
	Bolt size (assumption) (-)	M30	M30	M30	M30	M30	M30	M30	M30	M30	M36	M36	M36	M36	M39	M39
	Thickness of each reinforced steel plate (mm)	3.1	3.1	3.1	3.1	4.4	4.4	4.4	4.4	4.4	4.4	4.4	4.4	4.4	5.8	5.8
	Total height (mm)	265.9	277.9	286.9	295.9	353.6	362.6	379.6	391.6	400.6	425.6	447.6	468.6	537.2	694.7	
Total weight (tonf)	0.49	0.57	0.65	0.77	1.07	1.19	1.41	1.56	1.77	2.17	2.63	3.07	4.24	7.04		
Total weight (kN)	4.8	5.6	6.4	7.5	10.5	11.7	13.8	15.3	17.3	21.3	25.8	30.1	41.6	69.1		
Compression Properties	Critical stress [N/mm ²]	σ_c when $\gamma = 0$	65	63	64	65	63	64	65	64	64	63	64	65	69	
	Ultimate compressive stress [N/mm ²]	(γ_1, σ_1)	(0.00,60)	(0.00,60)	(0.00,60)	(0.00,60)	(0.00,60)	(0.00,60)	(0.00,60)	(0.00,60)	(0.00,60)	(0.00,60)	(0.00,60)	(0.00,60)	(0.00,60)	(0.00,60)
		(γ_1, σ_1)	(0.50,60)	(0.32,60)	(0.42,60)	(0.52,60)	(0.35,60)	(0.43,60)	(0.51,60)	(0.38,60)	(0.44,60)	(0.32,60)	(0.45,60)	(0.41,60)	(0.48,60)	(0.88,60)
		(γ_2, σ_2)	(4.00,25)	(4.00,24)	(4.00,25)	(4.00,26)	(4.00,24)	(4.00,25)	(4.00,25)	(4.00,24)	(4.00,25)	(4.00,24)	(4.00,25)	(4.00,25)	(4.00,25)	(4.00,27)
	Compressive stiffness (×10 ³ kN/m)		2280	2420	2640	2850	2990	3200	3420	3560	3770	4080	4510	4870	5290	6030
	Nominal long term compressive stress [N/mm ²]		15.0	15.0	15.0	15.0	15.0	15.0	15.0	15.0	15.0	15.0	15.0	15.0	15.0	15.0
	Nominal long term column load (kN)		4240	4970	5770	6620	7540	8510	9540	10600	11800	14200	16900	19900	23000	26500
Allowable tensile stress ($\gamma = 100\%$) [N/mm ²]		1.0	1.0	1.0	1.0	1.0	1.0	1.0	1.0	1.0	1.0	1.0	1.0	1.0	1.0	
Shear Properties	Shear stiffness (shear strain: $\gamma = \pm 100\%$) (×10 ³ kN/m)		0.923	0.985	1.07	1.15	1.22	1.30	1.38	1.45	1.53	1.67	1.84	1.99	2.32	

* : Special thickness for flange is available. Please refer to the table above for more details.

Description of the product designation

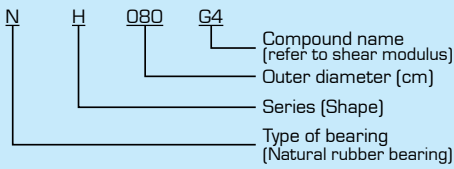

Specification of flange [edge thickness / center thickness]

Outer diameter of rubber bearing (∅)*1	(600)	(650)	700	750	800	850	900	950	1000	1100	1200	1300
Standard thickness	22/28	22/28	22/28	22/28	24/32	24/32	28/36	28/36	28/36	30/38	32/40	32/40
Special thickness (option)	[26/32]	[26/32]	26/32	30/36	32/40	32/40	37/45	37/45	42/50	42/50	42/50	42/50

*1 For adoption of special thickness in regard to those sizes that stated in the [], delivery time will be longer due to mold preparation.
 *2 For ∅1400 and above, assembled type flange will be used.
 *3 Compared to the standard specification, total height & weight of product for special thickness will be changed.

Certification number MVBR-0509/MVBR-0518 (G4)

Note: There are 2 certification numbers due to difference of some manufacturing process. Please refer to "Precautions" in page 11 for the certificate number that used for design document.

Code

Compound name	Rubber code	Shear modulus [N/mm ²]
G4	GO.40	0.392

●NH Series (Total Rubber Thickness 20cm)

Characteristics		NH060G4	NH065G4	NH070G4	NH075G4	NH080G4	NH085G4	NH090G4	NH095G4	NH100G4	NH110G4	NH120G4	NH130G4	NH140G4	NH150G4	
30Physical Dimensions	Outer diameter (mm)	600	650	700	750	800	850	900	950	1000	1100	1200	1300	1400	1500	
	Inner diameter (mm)	15	15	15	15	20	20	20	20	25	55	55	55	65	65	
	Effective plane area (×10 ² mm ²)	2826	3317	3847	4416	5023	5671	6359	7085	7849	9480	11286	13249	15361	17638	
	Thickness of one rubber layer (mm)	4.0	4.4	4.7	5.0	5.4	5.7	6.0	6.4	6.7	7.4	8.0	8.7	9.5	10.0	
	Number of rubber layers (-)	50	45	43	40	37	35	33	31	30	27	25	23	21	20	
	Total rubber thickness (mm)	200	198	202	200	200	200	198	198	201	200	200	200	200	200	200
	First shape factor (-)	36.6	36.1	36.4	36.8	36.1	36.4	36.7	36.3	36.4	35.3	35.8	35.8	35.1	35.9	
	Second shape factor (-)	3.00	3.28	3.46	3.75	4.00	4.26	4.55	4.79	4.98	5.51	6.00	6.50	7.02	7.50	
	Diameter of flange (mm)	900	950	1000	1100	1150	1200	1250	1300	1400	1500	1600	1700	1800	1900	
	Thickness of flange* (edge/center) (mm)	22/28	22/28	22/28	22/28	24/32	24/32	28/36	28/36	28/36	30/38	32/40	32/40	37/45	42/50	
	Connecting bolt PCD (mm)	775	825	875	950	1000	1050	1100	1150	1250	1350	1450	1550	1650	1750	
	Diameter of connecting bolt hole × qty (mm)	∅33 × 12	∅33 × 12	∅33 × 12	∅33 × 12	∅33 × 12	∅33 × 12	∅33 × 12	∅33 × 12	∅39 × 12	∅39 × 12	∅39 × 12	∅39 × 12	∅42 × 12	∅42 × 16	
	Bolt size (assumption) (-)	M30	M30	M30	M30	M30	M30	M30	M30	M36	M36	M36	M36	M39	M39	
	Thickness of each reinforced steel plate (mm)	3.1	3.1	3.1	3.1	4.4	4.4	4.4	4.4	4.4	4.4	4.4	4.4	5.8	5.8	
	Total height (mm)	407.9	390.4	388.3	376.9	422.2	413.1	410.8	402.4	400.6	390.2	385.6	376.9	405.5	410.2	
Total weight (tonf)	0.66	0.72	0.80	0.90	1.21	1.31	1.49	1.59	1.77	2.05	2.38	2.65	3.46	4.05		
Total weight (kN)	6.5	7.0	7.9	8.9	11.9	12.9	14.6	15.6	17.3	20.1	23.3	26.0	33.9	39.7		
Compression Properties	Critical stress (N/mm ²)	σ_c when $\gamma = 0$	31	35	38	43	47	51	56	61	64	70	77	84	90	97
	Ultimate compressive stress (N/mm ²)	(γ'_c, σ_c)	(0.00,31)	(0.00,35)	(0.00,38)	(0.00,43)	(0.00,47)	(0.00,51)	(0.00,56)	(0.00,60)	(0.00,60)	(0.00,60)	(0.00,60)	(0.00,60)	(0.00,60)	(0.00,60)
		(γ'_1, σ_1)	-	-	-	-	-	-	-	(0.07,60)	(0.44,60)	(1.08,60)	(1.76,60)	(2.42,60)	(3.05,60)	(3.74,60)
		(γ'_2, σ_2)	(2.76,0)	(3.21,0)	(3.46,0)	(3.75,3)	(4.00,5)	(4.00,10)	(4.00,16)	(4.00,21)	(4.00,25)	(4.00,32)	(4.00,38)	(4.00,44)	(4.00,51)	(4.00,57)
	Compressive stiffness (×10 ³ kN/m)		1370	1610	1840	2140	2420	2750	3110	3450	3770	4530	5420	6350	7330	8470
	Nominal long term compressive stress (N/mm ²)		6.0	7.0	7.8	8.9	9.8	10.8	12.0	13.0	15.0	15.0	15.0	15.0	15.0	15.0
	Nominal long term column load (kN)		1700	2320	3000	3930	4920	6130	7630	9200	11800	14200	16900	19900	23000	26500
Allowable tensile stress ($\gamma = 100\%$) (N/mm ²)		1.0	1.0	1.0	1.0	1.0	1.0	1.0	1.0	1.0	1.0	1.0	1.0	1.0	1.0	
Shear Properties	Shear stiffness (shear strain: $\gamma = \pm 100\%$) (×10 ³ kN/m)		0.554	0.657	0.746	0.866	0.986	1.11	1.26	1.40	1.53	1.86	2.21	2.60	3.02	3.46

* : Special thickness for flange is available. Please refer to the table above for more details.

Certification number MVBR-0509/MVBR-0518 (G4)

Note: There are 2 certification numbers due to difference of some manufacturing process.
Please refer to "Precautions" in page 11 for the certificate number that used for design document.

Code

Compound name	Rubber code	Shear modulus [N/mm ²]
G4	GO.40	0.392

NL Series (Total Rubber Thickness 16cm)

Characteristics		NL060G4	NL065G4	NL070G4	NL075G4	NL080G4	NL085G4	NL090G4	NL095G4	NL100G4	NL110G4	NL120G4	NL130G4	
3D Physical Dimensions	Outer diameter (mm)	600	650	700	750	800	850	900	950	1000	1100	1200	1300	
	Inner diameter (mm)	15	15	15	15	20	20	20	20	25	55	55	55	
	Effective plane area (×10 ² mm ²)	2826	3317	3847	4416	5023	5671	6359	7085	7849	9480	11286	13249	
	Thickness of one rubber layer (mm)	3.95	4.4	4.9	4.85	5.1	5.25	5.65	6.0	6.35	7.2	7.7	8.0	
	Number of rubber layers (-)	41	37	34	34	33	32	30	28	26	23	22	21	
	Total rubber thickness (mm)	162	163	167	165	168	168	170	168	165	166	169	168	
	First shape factor (-)	37.0	36.1	34.9	37.9	38.2	39.5	38.9	38.8	38.4	36.3	37.2	38.9	
	Second shape factor (-)	3.70	3.99	4.20	4.55	4.75	5.06	5.31	5.65	6.06	6.64	7.08	7.74	
	Diameter of flange (mm)	900	950	1000	1100	1150	1200	1250	1300	1400	1500	1600	1700	
	Thickness of flange (edge/center) (mm)	22/28	22/28	22/28	22/28	24/32	24/32	28/36	28/36	28/36	30/38	32/40	32/40	
	Connecting bolt PCD (mm)	775	825	875	950	1000	1050	1100	1150	1250	1350	1450	1550	
	Diameter of connecting bolt hole × qty (mm)	∅33×12	∅33×12	∅33×12	∅33×12	∅33×12	∅33×12	∅33×12	∅33×12	∅39×12	∅39×12	∅39×12	∅39×12	
	Bolt size (assumption) (-)	M30	M30	M30	M30	M30	M30	M30	M30	M36	M36	M36	M36	
	Thickness of each reinforced steel plate (mm)	3.1	3.1	3.1	3.1	4.4	4.4	4.4	4.4	4.4	4.4	4.4	5.8	
	Total height (mm)	342.0	330.4	324.9	323.2	373.1	368.4	369.1	358.8	347.1	338.4	341.8	364.0	
Total weight (tonf)	0.58	0.64	0.70	0.82	1.12	1.23	1.40	1.48	1.63	1.88	2.22	2.80		
Total weight (kN)	5.7	6.3	6.9	8.1	11.0	12.1	13.7	14.5	15.9	18.4	21.8	27.5		
Compression Properties	Critical stress [N/mm ²]	σ_c when $\gamma = 0$	42	46	49	57	61	68	71	75	80	86	93	103
	Ultimate compressive stress [N/mm ²]	(γ'_c, σ_c)	(0.00,42)	(0.00,46)	(0.00,49)	(0.00,57)	(0.00,60)	(0.00,60)	(0.00,60)	(0.00,60)	(0.00,60)	(0.00,60)	(0.00,60)	(0.00,60)
		(γ'_1, σ_1)	-	-	-	-	(0.13,60)	(0.77,60)	(1.06,60)	(1.50,60)	(2.01,60)	(2.64,60)	(3.29,60)	(4.00,60)
		(γ'_2, σ_2)	(3.70,2)	(3.99,5)	(4.00,9)	(4.00,16)	(4.00,21)	(4.00,27)	(4.00,30)	(4.00,35)	(4.00,40)	(4.00,47)	(4.00,53)	(4.00,60)
	Compressive stiffness	[×10 ³ kN/m]	1700	1960	2190	2630	2940	3360	3720	4170	4690	5520	6490	7810
	Nominal long term compressive stress	[N/mm ²]	8.7	9.7	10.5	12.1	13.0	15.0	15.0	15.0	15.0	15.0	15.0	15.0
	Nominal long term column load	[kN]	2460	3220	4040	5340	6530	8510	9540	10630	11800	14200	16900	19900
Allowable tensile stress ($\gamma = 100\%$)	[N/mm ²]	1.0	1.0	1.0	1.0	1.0	1.0	1.0	1.0	1.0	1.0	1.0	1.0	
Shear Properties	Shear stiffness [shear strain: $\gamma = \pm 100\%$]	[×10 ³ kN/m]	0.684	0.799	0.905	1.05	1.17	1.32	1.47	1.65	1.86	2.24	2.61	3.09

Specification of flange (edge thickness / center thickness)

Outer diameter of rubber bearing (Ø) ^{*1}	(900)	(950)	1000	1100	1200	1300
Standard thickness	28/36	28/36	28/36	30/38	32/40	32/40
Special thickness (option)	(37/45)	(37/45)	42/50	42/50	42/50	42/50

×1 For adoption of special thickness in regard to those sizes that stated in the (), delivery time will be longer due to mold preparation.
 ×2 For Ø1400 and above, assembled type flange will be used.
 ×3 Compared to the standard specification, total height & weight of product for special thickness will be changed.

Certification number MVBR-0509/MVBR-0518 (G4)

Note: There are 2 certification numbers due to difference of some manufacturing process.
 Please refer to "Precautions" in page 11 for the certificate number that used for design document.

Code

Compound name	Rubber code	Shear modulus [N/mm ²]
G4	G0.40	0.392

●NT Series (Total Rubber Thickness 25cm)

Characteristics		NT090G4	NT095G4	NT100G4	NT110G4	NT120G4	NT130G4	NT140G4	NT150G4	NT160G4	
30Physical Dimensions	Outer diameter (mm)	900	950	1000	1100	1200	1300	1400	1500	1600	
	Inner diameter (mm)	20	20	25	55	55	55	65	65	80	
	Effective plane area (×10 ² mm ²)	6359	7085	7849	9480	11286	13249	15361	17638	20056	
	Thickness of one rubber layer (mm)	6.0	6.4	6.7	7.4	8.0	8.7	9.5	10.0	10.4	
	Number of rubber layers (-)	42	39	37	34	31	29	26	25	24	
	Total rubber thickness (mm)	252	250	248	252	248	252	247	250	250	
	First shape factor (-)	36.7	36.3	36.4	35.3	35.8	35.8	35.1	35.9	36.5	
	Second shape factor (-)	3.57	3.81	4.03	4.37	4.84	5.15	5.67	6.00	6.41	
	Diameter of flange (mm)	1250	1300	1400	1500	1600	1700	1800	1900	2000	
	Thickness of flange* (edge/center) (mm)	28/36	28/36	28/36	30/38	32/40	32/40	37/45	42/50	50/110	
	Connecting bolt PCD (mm)	1100	1150	1250	1350	1450	1550	1650	1750	1800	
	Diameter of connecting bolt hole × qty (mm)	Ø33 × 12	Ø33 × 12	Ø39 × 12	Ø39 × 12	Ø39 × 12	Ø39 × 12	Ø42 × 12	Ø42 × 16	Ø45 × 12	
	Bolt size (assumption) (-)	M30	M30	M36	M36	M36	M36	M39	M39	M42	
	Thickness of each reinforced steel plate (mm)	4.4	4.4	4.4	4.4	4.4	4.4	5.8	5.8	5.8	
	Total height (mm)	504.4	488.8	478.3	472.8	460.0	455.5	482.0	489.2	603.0	
Total weight (tonf)	1.73	1.83	2.00	2.34	2.68	3.01	3.90	4.56	7.21		
Total weight (kN)	16.9	18.0	19.6	22.9	26.2	29.5	38.2	44.7	70.7		
Compression Properties	Critical stress [N/mm ²]	σ_{cr} when $\gamma = 0$	40	43	47	52	61	66	72	83	
	Ultimate compressive stress [N/mm ²]	(γ_1, σ_0)	(0.00,40)	(0.00,43)	(0.00,47)	(0.00,52)	(0.00,60)	(0.00,60)	(0.00,60)	(0.00,60)	(0.00,60)
		(γ_1, σ_1)	-	-	-	-	(0.13,60)	(0.65,60)	(1.28,60)	(1.77,60)	(2.36,60)
		(γ_2, σ_2)	(3.75,1)	(3.81,3)	(4.00,5)	(4.00,12)	(4.00,22)	(4.00,27)	(4.00,34)	(4.00,38)	(4.00,44)
	Compressive stiffness	(×10 ³ kN/m)	2440	2740	3060	3600	4370	5040	5920	6780	7770
	Nominal long term compressive stress	(N/mm ²)	8.2	9.0	9.9	11.2	13.1	15.0	15.0	15.0	15.0
	Nominal long term column load	(kN)	5210	6380	7770	10600	14800	19900	23000	26500	30100
Allowable tensile stress ($\gamma = 100\%$)	(N/mm ²)	1.0	1.0	1.0	1.0	1.0	1.0	1.0	1.0	1.0	
Shear Properties	Shear stiffness (shear strain: $\gamma = \pm 100\%$)	(×10 ³ kN/m)	0.989	1.11	1.24	1.48	1.78	2.06	2.44	2.77	3.15

* : Special thickness for flange is available. Please refer to the table above for more details.

Certification number MVBR-0509 (G4)

Code

Compound name	Rubber code	Shear modulus (N/mm ²)
G4	G0.40	0.392

●ND Series (Total Rubber Thickness 32cm)

Characteristics		ND160G4	ND170G4	ND180G4	
30Physical Dimensions	Outer diameter (mm)	1600	1700	1800	
	Inner diameter (mm)	80	85	5 – Ø 55	
	Effective plane area (×10 ² mm ²)	20056	22641	25328	
	Thickness of one rubber layer (mm)	10.4	10.4	11.1	
	Number of rubber layers (-)	31	31	29	
	Total rubber thickness (mm)	322	322	322	
	First shape factor (-)	36.5	38.8	35.0	
	Second shape factor (-)	4.96	5.27	5.59	
	Diameter of flange (mm)	2000	□ 1980	□ 2080	
	Thickness of flange (edge/center) (mm)	50/100	50/100	50/100	
	Connecting bolt PCD (mm)	1800	-	-	
	Diameter of connecting bolt hole × qty (mm)	Ø 45 × 12	Ø 45 × 24	Ø 45 × 24	
	Bolt size (assumption) (-)	M42	M42	M42	
	Thickness of each reinforced steel plate (mm)	5.8	5.8	5.8	
	Total height (mm)	696.4	696.4	684.3	
	Total weight (tonf)	7.69	9.02	9.79	
Total weight (kN)	75.4	88.4	96.0		
Compression Properties	Critical stress (N/mm ²)	σ_{cr} when $\gamma = 0$	64	70	71
	Ultimate compressive stress (N/mm ²)	(γ'_0, σ_0)	(0.00,60)	(0.00,60)	(0.00,60)
		(γ'_1, σ_1)	(0.43,60)	(1.01,60)	(1.17,60)
		(γ'_2, σ_2)	(4.00,25)	(4.00,30)	(4.00,33)
	Compressive stiffness	(×10 ³ kN/m)	6020	6950	7480
	Nominal long term compressive stress (N/mm ²)		15.0	15.0	15.0
	Nominal long term column load (kN)		30100	34000	38000
Allowable tensile stress ($\gamma = 100\%$) (N/mm ²)		1.0	1.0	1.0	
Shear Properties	Shear stiffness (shear strain: $\gamma = \pm 100\%$) (×10 ³ kN/m)	2.44	2.75	3.08	

Description of the product designation for laminated rubber

Description of the product designation for sliding plate

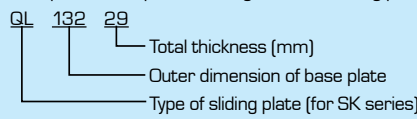
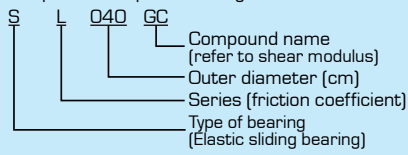

Elastic Sliding Bearing

Certification Number MVBR-0349

Code

Compound name	Rubber code	Shear modulus [N/mm ²]
GC	G1.2	118

●SL Series ($\mu = 0.13$, G1.2)

Characteristics		SL030GC	SL040GC	SL050GC	SL060GC	SL070GC	SL080GC
Physical Dimensions of Laminated Rubber	Outer diameter (mm)	300	400	500	600	700	800
	Inner diameter (mm)	0	0	0	0	0	0
	Effective diameter (mm)	300	400	500	600	700	800
	Effective plane area*1 [$\times 10^2$ mm ²]	707	1257	1963	2827	3848	5027
	Thickness of one rubber layer (mm)	3.5	5.0	6.0	7.5	8.7	10.0
	Number of rubber layers (-)	12	12	10	8	7	6
	Total rubber thickness (mm)	42	60	60	60	61	60
	First shape factor (-)	21.4	20.0	20.8	20.0	20.1	20.0
	Second shape factor (-)	7.14	6.67	8.33	10.0	11.5	13.3
	Diameter of sliding material (PTFE) (mm)	308	408	508	608	708	808
	Diameter of flange (mm)	500	650	750	900	1000	1150
	Thickness of flange (mm)	16/22	16/22	22/28	22/28	22/28	24/32
	Connecting bolt PCD (mm)	420	550	650	775	875	1000
	Diameter of connecting bolt hole \times qty (mm)	$\varnothing 27 \times 8$	$\varnothing 27 \times 8$	$\varnothing 27 \times 8$	$\varnothing 33 \times 8$	$\varnothing 33 \times 8$	$\varnothing 33 \times 8$
	Bolt size (assumption) (-)	M24	M24	M24	M30	M30	M30
	Thickness of each reinforced steel plate (mm)	2.2	2.2	2.2	3.1	3.1	3.1
	Height of laminated rubber (mm)	103.2	121.2	122.8	132.7	130.5	130.5
	Weight of laminated rubber (tonf)	0.05	0.10	0.15	0.24	0.31	0.41
Weight of laminated rubber (kN)	0.5	0.9	1.5	2.4	3.0	4.0	
Ultimate displacement (mm)	(Outer dimension of SUS plate – Outer diameter of laminated rubber) / 2, (Max displacement = ± 700 mm)						
Compression Properties	Ultimate compressive stress [N/mm ²]	50					
	Nominal long term compressive stress [N/mm ²]	10*2					
	Nominal long term column load (kN)	707	1260	1960	2830	3850	5030
	Compressive stiffness [$\times 10^3$ kN/m]	1730	2040	3290	4600	6190	8170
Shear Properties	Allowable tensile stress [N/mm ²]	0					
	Initial stiffness [$\times 10^3$ kN/m]	1.98	2.46	3.85	5.55	7.44	9.86
Friction Coefficient	Post yield stiffness [$\times 10^3$ kN/m]	0					
	Dynamic friction coefficient (-)	0.13 (compressive stress $\sigma = 10$ [N/mm ²], velocity $V = 100$ [mm/s])					

*1 Effective plane area is calculated based on effective diameter (outer diameter of sliding material)

*2 Nominal long term compressive stress is referred as long term upper limit of compressive stress.

Sliding plate (SUS finished product of #400) can be used in combination of the following specifications in correspond to the ultimate deformation.

Characteristics		QL13228	QL14228	QL15228	QL16231	QL17231	QL18231	QL19231	QL20231	QL21231	QL22231	
Physical Dimensions of Sliding Plate	Outer dimension of base plate (mm)	$\square 1320$	$\square 1420$	$\square 1520$	$\square 1620$	$\square 1720$	$\square 1820$	$\square 1920$	$\square 2020$	$\square 2120$	$\square 2220$	
	Outer dimension of SUS plate (mm)	$\square 1300$	$\square 1400$	$\square 1500$	$\square 1600$	$\square 1700$	$\square 1800$	$\square 1900$	$\square 2000$	$\square 2100$	$\square 2200$	
	Inner dimension of SUS plate (mm)	550	600	650	700	750	800	850	900	950	1000	
	Total thickness (mm)	28	28	28	31	31	31	31	31	31	31	
	Connecting bolt hole position	L_{b1} (mm)	1000	1100	1200	1300	1400	1500	1600	1700	1800	1900
		L_{b2} (mm)	1200	1300	1400	1500	1600	1700	1800	1900	2000	2100
	Diameter of connecting bolt hole \times qty (mm)	$\varnothing 35 \times 8$	$\varnothing 35 \times 8$	$\varnothing 35 \times 8$	$\varnothing 41 \times 8$	$\varnothing 41 \times 8$	$\varnothing 41 \times 8$	$\varnothing 41 \times 8$	$\varnothing 41 \times 8$	$\varnothing 41 \times 8$	$\varnothing 41 \times 8$	$\varnothing 41 \times 8$
	Bolt size (assumption) (-)	M30	M30	M30	M36	M36	M36	M36	M36	M36	M36	M36
	Weight of sliding plate (tonf)	0.38	0.44	0.50	0.62	0.70	0.78	0.87	0.96	1.06	1.16	
	Weight of sliding plate (kN)	3.7	4.3	4.9	6.1	6.8	7.7	8.5	9.4	10.4	11.4	

Longer delivery time may be required if the outside dimension of SUS plate exceeds $\square 2000$ mm. Separately, we do offer dust-proof cover (please refer to page 72 for more details).

Compact Flange Type

●Characteristic

■Installation space improvement

It could save space during installation because the flange size has been minimized in compact shape. Reduction of footing size is possible especially in the retrofit project, edge part's placement & etc.

■Round shape of rubber bearing

Because of round-shape of rubber bearing, there is no change of shear characteristics due to direction.

●Line-up

Line-up is for the flange-integrated seismic isolation bearing. Please contact us for any size that isn't listed in the table below.

■Supports many types of seismic isolation rubber bearing

Any size can be selected from Bridgestone's product range.

※Compared to round-shape flange, compact flange has some limitations in the strength of the flange, displacement of rubber bearing & etc. Please contact us for more details.

Certification Number	Series	Size (diameter of rubber bearing)	Type of Rubber	Performance
MVBR-0510/MVBR-0519 MVBR-0514/MVBR-0520	HDR	Ø600 - Ø1300	X4S X6R	Equivalent to Bridgestone seismic isolation rubber (round-shape flange)
MVBR-0509/MVBR-0518 MVBR-0295	NRB	Ø600 - Ø1300	G4 N3, G3, G5	
MVBR-0517	LRB	Ø600 - Ø1300	G4	

※ For Ø1400 and above, assembled type flange will be used.

●Flange Size Table

Diameter of rubber bearing	600	650	700	750	800	850	900	950	1000	1100	1200	1300
Diameter of round-shape flange (D)	900	950	1000	1100	1150	1200	1250	1300	1400	1500	1600	1700
Length of one side of a compact flange (L)	745	795	845	910	965	1010	1055	1100	1200	1290	1380	1470
D - L	155	155	155	190	185	190	195	200	200	210	220	230

Comparison Between Compact Flange and Round-shape Flange

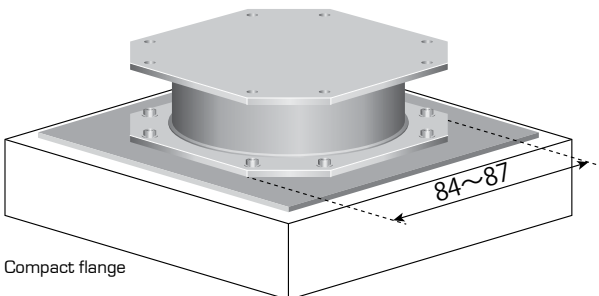

Compact flange

●Comparison of flange's dimension

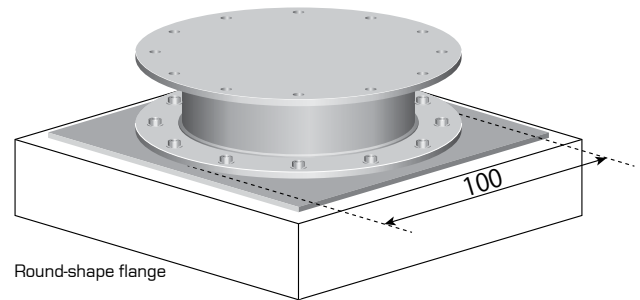

Round-shape flange

●View of reinforcement bar arrangement

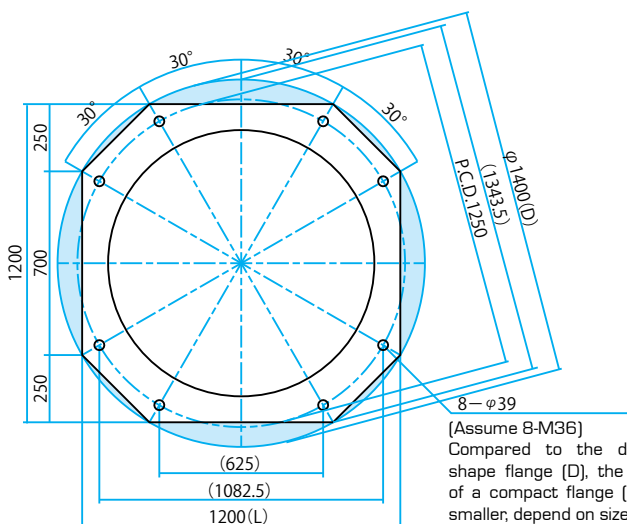

(Assume 8-M36)
Compared to the diameter of round-shape flange (D), the length of one side of a compact flange (L) is about 13-16% smaller, depend on sizes.
(This figure is an example of rubber diameter Ø1000)

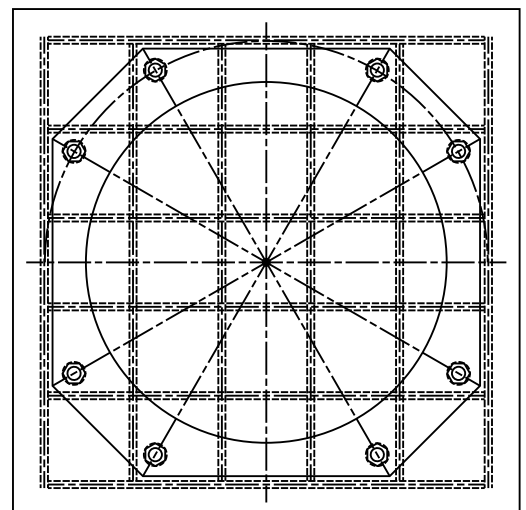

View of reinforcement bar arrangement with span of 180-200mm.

Dustproof Cover for Elastic Sliding Bearing

●Characteristic

■ Superior workability

It is composed of 2.0mm thick polyvinyl chloride and base fabric only, easy to carry and excellent workability including easily detach during maintenance.

■ Flame resistance

With self-extinguishing properties, polyvinyl chloride can prevent the spread of fire in the event of fire.

■ Other Characteristics

It helps to clean the dirt or dust on the surface since elastic sliding bearing and "dustproof cover SD" move together during earthquake, and it does not affect the sliding surface.

Compared to conventional product, we had shortened the lead time.

■ Dustproof

"Dustproof cover SD" are arranged to cover the surface of sliding plate without a gap, so that dirt or dust does not deposit on the surface.

■ Durability

Polyvinyl chloride is excellent in durability and there is almost no degradation in strength. It can be used for a long period of time with peace of mind.

□ Precaution

Because of polyvinyl chloride, it requires high-temperature treatment for disposal.

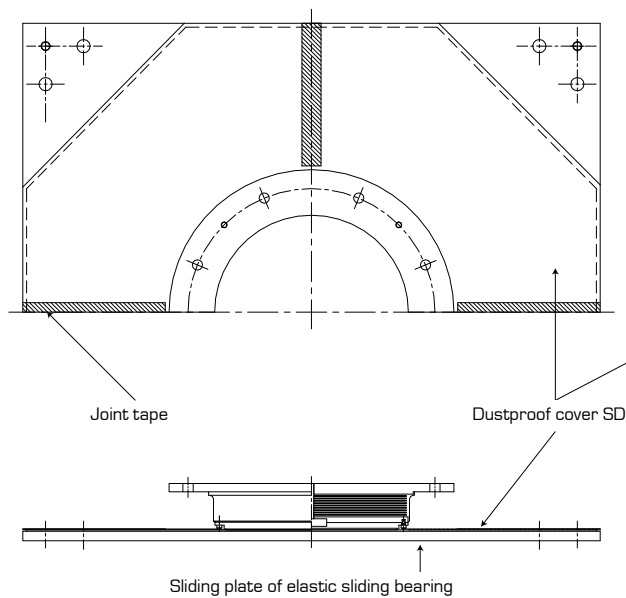

Example of installation



Precautions for Safe Use of Seismic Isolation Bearing (SIB)

- The term “SIB” as used in this precautions means seismic isolation bearing for seismically isolated building, including sliding bearing.

⚠ WARNING	Failure to follow these precautions may result in death or serious injury.
SIB is heavy. Falling or rolling SIB may cause death or serious injury.	
<ul style="list-style-type: none"> ■ Always be careful when you move SIB. <ul style="list-style-type: none"> • Transport SIB one by one. If not, it becomes unstable. ■ When lifting the SIB with a crane or others, observe the followings. <ul style="list-style-type: none"> • Use a crane or a suspending jig (eyebolt or others) corresponding to the product weight of the SIB, and use the bolt hole of SIB flange and hoist at 4 points or more. If not, it becomes unstable. • Sufficiently check the safety of the surroundings beforehand so that no one enters around the suspended load. 	
Rubber part of SIB is flammable. Ignition / catch fire on SIB may cause fire or burn.	
<ul style="list-style-type: none"> • Be away from a fire and do not weld the flange part or such like. 	

NOTICE	Failure to follow these precautions may result in damage to other property, or damage, low performance, malfunction or early deterioration in durability of SIB itself.
<ul style="list-style-type: none"> • Do not apply large impact (falling, collision, etc.) to SIB. Damaged SIB may cause function deterioration of the SIB and an early deterioration in durability. • Do not roll the SIB or twist it with iron lever or bar. Damaged SIB may cause function deterioration and an early deterioration in durability. • Be careful not to damage the SIB with other equipment (such as a cutter when packaging removal). Damaged SIB may cause function deterioration of the SIB and an early deterioration in durability. • In case of outdoor storage, be sure to take measures against rain. Due to wetting with rainwater, it may cause an early deterioration in durability to the flange antirust coating part. • Do not expose the SIB to a temporary high temperature condition (about 100 ° C or higher). Due to the influence of heat, the rubber part of the SIB may be damaged, which may cause function deterioration of the SIB and an early deterioration in durability. • When tightening the bolt in SIB installation work, do not damage the flange antirust coating part with bolt / washer fastening jig or others. It may cause an early deterioration in durability to the flange antirust coating part. • Install the SIB so that the horizontal inclination of the foundation becomes less than 1/400 in inclination accuracy. (Except when our company acknowledges in advance.) When mounted in an inclined, SIB may not function properly (function deterioration may occur). • Do not apply or adhere oils, solvents etc. to the rubber part. Due to deterioration, dissolution etc. of the rubber part may cause function deterioration of the SIB and an early deterioration in durability. • Do not scratch the coating part of the sliding plate when removing the packing of the sliding plate of sliding bearing. Damage of the coating part may cause function deterioration and an early deterioration in durability. • If the residual displacement after the earthquake is equal to or greater than the preset displacement (standard 5 cm), promptly take measures to restore it to the origin. It may cause function deterioration of the SIB and an early deterioration in durability. • After installing SIB, consider aeration and ventilation as much as possible inside seismic isolation interface, and remove moisture by condensation as necessary. It may cause an early deterioration in durability to the flange antirust coating part. • Carry out proper maintenance as prescribed in the design document (building completion inspection · normal inspection · periodical inspection · emergency inspection · detailed inspection etc. by experts). It is necessary to periodically check whether events that may cause function deterioration of the SIB and an early deterioration in durability have occurred. 	

- Specification and parameter may vary. Please enquire our company or any group's subsidiary whenever want to use it.
- Content of catalogue is as on January 2017.

Bridgestone Corporation

Seismic Isolation & Vibration Control Products Business Department

Yaesu Center Bldg. 11F, Yaesu, Chuo-ku, Tokyo 103-0028, Japan

TEL: +81-3-5205-6865 FAX: +81-3-5202-6848

EMAIL: zzy310.menshin@bridgestone.com

URL: http://www.bridgestone.com/products/diversified/antiseismic_rubber/index.html

MORE INFORMATION ON SEISMIC <http://www.menshin-channel.com/index.html>

Bridgestone Engineered Products of Asia Sdn Bhd

L1-E-3B, Enterprise 4, Technology Park Malaysia,

Lebuhraya Puchong-Sg. Besi, Bukit Jalil,

57000 Kuala Lumpur, Malaysia.

TEL: +60-3-8996-2670 FAX: +60-3-8996-2690

EMAIL: info@bridgestone.com.my

Bridgestone Engineered Products of Asia Sdn Bhd (Australia)

Unit 17/27 Old Great Northern highway,

Midland WA 6056,

P.O Box 2325 Midland WA 6936

TEL: +61-8-9250-0600 FAX: +61-8-9250-0601

EMAIL: info@bsea.com.au

PT. Bridgestone Mining Solutions Indonesia

Wisma Nusantara Building 12th floor,

Jl. M.H. Thamrin No. 59, Jakarta 10350, Indonesia

TEL: +62-21-3190-8077 FAX: +62-21-3983-5881

Bridgestone Engineered Products of Asia Sdn Bhd (India)

Office No. 404, 4th Floor, Time Tower,

Mehrauli Gurgaon Road,

Gurgaon-122001, India

TEL: +91-124-4262321/+91-124-426232

EMAIL: info@bridgestone.com.my

Bridgestone Diversified Products Japan Co., Ltd.

Taiwan branch

6F-2, No.41,

Nanking W.Rd,

Taipei, Taiwan, R.O.C

TEL: +886-2-2556-3459 FAX: +886-2-2556-3487

BRISA Bridgestone Sabanci Tyre Manufacturing and

Trading Inc (Turkey)

Kısıklı Cad. Şehit Teğmen İsmail Moray Sok.,

No:2/1, 34662 Altunizade,

Istanbul, Turkey

TEL: +90-216-544-3500/2192 FAX: +90-216-544-3535
